

# Matrix Digital MDM<sup>®</sup> Nitrous Oxide/Oxygen Sedation Flowmeter

## Instructions for Use and Installation Guide



# Representation

	<b>Legal Manufacturer</b>	Parker Hannifin Corporation Precision Fluidics Division 245 Township Line Road Hatfield, PA 19440 USA Office: (215) 723-4000
	<b>European Communities Authorized Representative</b>	EMERGO Europe Westervoortsedijk 60 6827 AT Arnhem, The Netherlands Tel: +31 70 345 8570
	<b>Conformité Européenne (CE) Mark</b>	Compliance with conformity assessment on quality management system and technical documentation per Regulations (EU) 2017/745 for Medical Device, Annex IX Chapters I & III
	<b>Switzerland Authorized Representative</b>	Medenvoy Gotthardstrasse 28 6302 Zug Switzerland +41 41 562 01 42

# READ INSTRUCTIONS FOR USE COMPLETELY BEFORE OPERATING THIS DEVICE

This document contains warnings, cautions, instructions for use, and maintenance information that the user must completely comprehend before using this device. Failure to properly operate and maintain this device may result in patient/user harm and/or damage to equipment.

## Table Of Contents

1.	Device Information.....	4
1.1.	Intended Use/Intended Purpose.....	4
1.2.	Models.....	4
1.3.	User Interface.....	5
1.4.	General Description/Principles of Operation.....	5
1.5.	Use of the Device.....	6
1.6.	Patient Population.....	6
1.7.	Warnings and Cautions.....	7
1.8.	Safety Features.....	7
1.9.	Delivery Protocols.....	8
1.10.	Safe Combination of devices.....	8
1.11.	Specifications.....	9
2.	Installation Instructions.....	10
2.1.	Compatible Mounting Accessories.....	10
2.2.	Mounting the Digital MDM Flowmeter.....	10
2.3.	Connecting Supply Lines.....	11
3.	Instructions for Use.....	12
3.1.	Setup and Prechecks.....	12
3.2.	Operating Instructions.....	13
4.	Maintenance.....	14
4.1.	Pre-Check.....	15
4.2.	Fuse Replacement.....	18
4.3.	Cleaning.....	18
4.4.	Troubleshooting: Error Codes.....	19
4.5.	Disposal.....	19
5.	Material Residual Risks.....	19
6.	Symbols Glossary.....	20
7.	Warranty.....	23



**WARNING:** This product can expose you to chemicals, including lead and nickel which are known to the State of California to cause cancer and birth defects or other reproductive harm. For more information, go to [www.P65Warnings.ca.gov](http://www.P65Warnings.ca.gov).



**WARNING:** This product contains the presence of SVHCs, phthalates/DEHPs, CMR, and EDC in excess of 0.1% weight-by-weight material composition. For more information, including precautionary measures for at risk patients, refer to **Section 5. Material Residual Risks**.



**CAUTION:** Federal law restricts this device to sale by or on the order of a physician or dentist.



Visit our website: <https://www.porterinstrument.com/upright-flowmeters> for additional information.

To download Instructions for Use: visit <https://www.porterinstrument.com/dental-support> Choose "Flowmeter" from the dropdown within the "Product Download" section.

# 1. Device Information

## 1.1. Intended Use/Intended Purpose

The Digital MDM Flowmeter is intended for use as a continuous flow system to deliver a mixture of nitrous oxide and oxygen gases to a conscious, spontaneously breathing patient.

## 1.2. Models

The Digital MDM Flowmeter is available in 11 flowmeter models and 14 flowmeters and bag-tee models (described below). Flowmeters are available with different fitting configurations and minimum percentage oxygen (O<sub>2</sub>). Throughout this document, the 40151601, USA fitting, 30% O<sub>2</sub> is pictured. All instructions and information are the same for all models unless specified otherwise.

**Device Model Table**

Model Type	Model Number	Model Description
Flowmeter	40151602*	DMDM BASIC ASSY,30 PCT, ST FT,2
	40151603	DMDM BASIC ASSY,30 PCT, L FIT,1
	40151604*	DMDM BASIC ASSY,30 PCT, L FIT,2
	40151614*	INTL DMDM BASIC ASSY, SWEDEN
	40151615*	INTL DMDM BASIC ASSY, AUSTRALIA
	40151616*	INTL DMDM BASIC ASSY,50% DUTCH
	40151617*	INTL DMDM BASIC ASSY,30 CANADA
	40151618*	INTL DMDM BASIC ASSY,30% ITALY
	40151619	INTL DMDM BASIC ASSY, 30
	40152601	DMDM REMOTE ASSY,30 PCT
	40151601	DMDM BASIC ASSY,30 PCT
	40151602SPAIN	INTL DMDM (STAND)-SPAIN
	40151601 KOR	DMDM BASIC ASSY,30%, KOREA
	Flowmeter and Bag Tee	91525176*
91525178*		DIGITAL MDM 30% GERMANY
91525179*		INTL DMDM (STAND)-SPAIN
91525180*		INTL DMDM 40% STAND-SWEDEN
91525182*		INTL DMDM (STAND)-ISRAEL
91525184*		INTL DMDM, STANDARD-AUSTRALIA
91525185*		INTL DMDM (STAND)-DUTCH
91525186*		INTL DMDM (STAND)-CANADA
91525187*		INTL DMDM, CABINET MOUNT
91525262*		INTL DMDM 30%(STAND)-ITALY
91525265*		INTL DMDM (STAND)-MIDDLE EAST
91525115 KOR		DIGITAL MDM ASSY-120V, KOREA

\*Denoted as CE Certified and available on European Market. Other models may be available on other international markets.

**Accessories Model Table**

Accessories	Model Number	Model Description
Wall Mount	2020	Telescope Wall Mount
Mobile Stands	2040*	Mobile Stand, Compact
2-Cylinder Mobile Carts	2100*	2-Cylinder Cart
	2100-2	2-Cylinder Cart with Dual Regulators and Hoses
	2100-N	2-Cylinder Cart with Nitrous Oxide Regulator
	2100-NC	2-Cylinder Cart, Nitrous Oxide Regulator and Hoses
	2100-ISO-2*	2-Cylinder Mobile Cart with Regulator O2, Regulator N2O, and Gas Supply Hoses
	2100-ISO-N*	2-Cylinder Mobile Cart with Regulator, N2O, and Gas Supply Hose
E-Stands	2045-3	E-Stand, Tall

Accessories	Model Number	Model Description
	2045-3CA	E-Stand, White Hose
	2045-3ISO*	E-Stand, Tall with Gas Supply Hoses

\*Denoted as CE Certified and available on European Market. Other models may be available on other international markets.



**WARNING:** The device has been validated with the above accessories. The use of alternatives could result in an unacceptable risk.

### 1.3. User Interface

#	Description
1	N <sub>2</sub> O and O <sub>2</sub> Gas Flow Indicators
2	Notification Display (Nitrous, Failure, 1 LPM Oxygen, Limit Flush, Flow Low)
3	% O <sub>2</sub> Control Buttons
4	% O <sub>2</sub> Display
5	LPM Flow Display
6	Flow Control Buttons
7	Flow Indicator (Total LPM)
8	On/Off Button
9	Flow Display Control Buttons
10	Notification Alert Test/Silence Button
11	O <sub>2</sub> Flush Button
12	Breathing Bag Port
13	Breathing Circuit Port

### 1.4. General Description/Principles of Operation

The Digital MDM Flowmeter is a pneumatically driven gas mixing device that delivers a mixture of nitrous oxide (N<sub>2</sub>O) and oxygen (O<sub>2</sub>) to a conscious, spontaneously breathing patient. The device is powered by compressed N<sub>2</sub>O and O<sub>2</sub> gas. Pressure is regulated within the device and gas is delivered to a patient at a low pressure. The device functions under the continuous flow principles of operation: when in use, the flowmeter will deliver gas on a continuous basis unless otherwise acted on by the healthcare professional.

The Digital MDM Flowmeter controls the flowrate of N<sub>2</sub>O and O<sub>2</sub> gases using firmware and electronic controls. The device features an auto-compensation, pneumatic mixer technology that maintains flowrate and gas mixture percentage when the user changes these parameters using the user interface. Internal valves control gas mixture percentage and flowrate to supply mixed gas to the patient. The mixed gas flows into the connected breathing bag which a patient draws from through the connected breathing circuit.

The Digital MDM Flowmeter is equipped with various safety features, which are described in Section 1.7.

## 1.5. Use of the Device

The Digital MDM Flowmeter is to be used by a healthcare professional trained in the use and administration of N<sub>2</sub>O and O<sub>2</sub> gases. The device is designed for use in a gas delivery and scavenging system for pain management and / or minimal conscious sedation, which is ideal for short, minimally invasive procedures to alleviate patient anxiety or minor pain and discomfort. It is the responsibility of the medical professional to consider the side effects, contraindications, and risks associated with administration of N<sub>2</sub>O and use of conscious sedation.

The Digital MDM Flowmeter is not used for the administration of general anesthesia or as part of, or in conjunction with, a general anesthesia administration system. The user should observe the patient to prevent over sedation in the event of an O<sub>2</sub> failsafe malfunction or crossed lines. If a patient becomes overly sedated when being delivered 100% O<sub>2</sub>, immediately remove the nasal hood and encourage mouth breathing. This is an indication of a failsafe malfunction or crossed lines; in this case, only deliver pure O<sub>2</sub> from an independent source.



**WARNING:** Do not use this device for the administration of general anesthesia or as part of, or in conjunction with, a general anesthesia administration system.

The user interface consists of a front panel with a keypad to display and control gas flowrate, gas mixture, and status. Keypad buttons may be pressed briefly or pressed and held to continue advancing inputs. The LPM flow display will show the total gas flowrate. It also shows the individual N<sub>2</sub>O and O<sub>2</sub> flowrates when either the N<sub>2</sub>O or O<sub>2</sub> flow display control buttons are pressed. The gas flowrate being displayed is indicated in the flow indicator by O<sub>2</sub>, total, or N<sub>2</sub>O. The percent O<sub>2</sub> display indicates the O<sub>2</sub> concentration set point in the total flowrate. Gas flowrate is indicated by bar graph LEDs. A green bar graph represents O<sub>2</sub> while blue represents the N<sub>2</sub>O flowrate. The number of lit bars gives a graphical indication of the flowrate level of a gas.

If any errors are detected, the unit displays EE on the percent O<sub>2</sub> display and an error code on the flowrate display.



**CAUTION:** Operate keypad with finger pressure only. Do not use hard or sharp objects. Otherwise, damage may result to the user interface.

**NOTE:** If a serious incident (death or any intervention) has occurred while the device was in use, it should be reported to the manufacturer immediately and the Competent Authority of the member state in which the serious incident occurred.

## 1.6. Patient Population

The patient population includes conscious, spontaneously breathing, awake, alert, and cooperative patients.

Patients are selected by a medical professional trained in the use and administration of nitrous oxide and oxygen gases. The medical professional must consider patients who are able to receive the gas mixture based on the risks associated with conscious sedation.

## 1.7. Warnings and Cautions

Warnings and cautions are listed where relevant to a certain section of this document.

A **WARNING** is an instruction, procedure, or explanation of hazards that may result in injury.

A **CAUTION** is an instruction, procedure, or explanation of hazards that may result in damage to a product, equipment, or the environment.



**WARNINGS** and **CAUTIONS** are presented throughout the document along with this symbol to alert the reader of their presence.

## 1.8. Safety Features

The performance of the Digital MDM Flowmeter is reflective of basic safety to provide a minimum of 20.9% oxygen while nitrous oxide is flowing. The safety features below ensure the device provide basic safety.

### **Failsafe:**

The Digital MDM Flowmeter utilizes a combination of software and electronics to ensure that the device only supplies N<sub>2</sub>O when O<sub>2</sub> flow is present. If the O<sub>2</sub> supply gas is depleted or disconnected, the device will discontinue mixed gas delivery until O<sub>2</sub> flow is restored.

### **DISS Fittings:**

The Digital MDM Flowmeter is equipped with Diameter Indexed Safety System (DISS) fittings, which act in a key-like fashion to ensure that each correct hose can be connected to the correct appropriate fitting. This prevents an accidental crossing of the N<sub>2</sub>O when O<sub>2</sub> gas lines.

### **Non-Rebreathing Check Valve:**

The non-rebreathing valve contains a backflow check valve to prevent exhaled gases from entering the breathing bag preventing carbon dioxide (CO<sub>2</sub>) buildup.

### **Emergency Air Intake Valve:**

In the event that the O<sub>2</sub> gas supply is depleted or disconnected, and delivery of mixed gas is stopped, an Emergency Air Intake Valve will open that allows the patient to breathe room air through the breathing circuit.

### **Onboard Diagnostics:**

The Digital MDM Flowmeter uses onboard diagnostics to conduct self-checks at start-up and during operation. When an issue is detected, a notification will appear in the Notification Display and is accompanied by a continuous, audible alert. A notification may be silenced but it will resume in five minutes until the cause is corrected.

- **Nitrous Failure** indicates the set N<sub>2</sub>O flowrate cannot be delivered. This is a self-canceling notification once N<sub>2</sub>O flowrate is restored.
- **1 LPM Oxygen Limit** indicates O<sub>2</sub> flowrate is reduced to 1 LPM.
- **Flush Flow Low** indicates O<sub>2</sub> Flush flowrate is reduced to less than 10 LPM.
- **Oxygen Failure** indicates the set O<sub>2</sub> flowrate cannot be delivered. This is a self-canceling notification once O<sub>2</sub> flowrate is restored



**WARNING:** The Digital MDM Flowmeter is not intended to be used during an MR exam and has not been evaluated for safety and compatibility in the MR environment. The safety of the Digital MDM Flowmeter in the MR environment is unknown, but due to the presence of materials in the device that may be ferromagnetic, the Digital MDM Flowmeter should be considered “MR Unsafe” and should be kept outside of any MRI scanner rooms.



**WARNING:** Workers exposed to N<sub>2</sub>O may suffer harmful effects. The healthcare professional is responsible for employing proper techniques, such as scavenging, room ventilation, system maintenance, and patient compliance to reduce exposure (ACGIH recommends a Threshold Limit Value of 50 parts per million over an 8-hour time-weighted average).



**WARNING:** The Digital MDM Flowmeter are used with the delivery of Oxygen (O<sub>2</sub>). Therefore, when this device is used in conjunction with energy producing devices (such as lasers, radio frequency sources, or other heat sources), the user must adhere to the instructions for use of those devices to avoid ignition of combustible materials.

## 1.9. Delivery Protocols

It is the responsibility of the medical establishment and the healthcare professional to develop specific delivery protocols for administration of N<sub>2</sub>O using the Digital MDM Flowmeter. Specific delivery protocols for adult and pediatric patients should be developed. The Digital MDM Flowmeter may be used for common dental procedures (ex. extractions, implants, fillings, etc.) on which the maximum use is less than 24-hours, typically less than 60-minutes.

## 1.10. Safe Combination of devices

The Digital MDM Flowmeter is designed to be used within a nitrous oxide/oxygen conscious sedation delivery and scavenging system to deliver an accurate mixture of nitrous oxide and oxygen gases to a conscious, spontaneously breathing patient. The device system is also used to remove exhaled waste analgesic gas through a vacuum control system. The system is comprised of a series of devices and accessories, which includes a conscious sedation flowmeter, bag tee and breathing bag, breathing circuit with nasal hood, vacuum controller, mounting stand, and gas supply hoses.

To ensure safe combination of device, user should follow the installation instructions in **Section 2** below and ensure all connections are secure and tight.

## 1.11. Specifications

### Dimensions

8.0 in W x 5.5 in H x 10.0 in D  
(20.32 cm W x 13.97 cm H x 25.40 cm D)

### Mixture Settings

N<sub>2</sub>O: 0% - (50%/60%/70%) (model based)  
O<sub>2</sub>: (30%/40%/50%) - 100% (model based)

### Delivery Accuracy (50–55 psi)

O<sub>2</sub> Flowrate: 1.0 - 9.9 ±0.5 LPM  
N<sub>2</sub>O Flowrate: 1.0 - 7.0 LPM ±0.5 LPM  
N<sub>2</sub>O Flowrate: 0.1 - 1.0 LPM +0.5/-0.9 LPM  
% O<sub>2</sub>: ±5% points @ N<sub>2</sub>O > 1.0 LPM  
% O<sub>2</sub>: +20/-10% points @ N<sub>2</sub>O < 1.0 LPM

### Atmospheric Pressure

1 atm ±0.2 atm (101 kPa ±20 kPa)

### Ingress Protection Rating

IPX0

### DMDM Flowmeter Power Supply (Internal)

P/N: 20197100

### Connection Fittings

#### Inlet Types (varies by model)

##### O<sub>2</sub> Inlet:

- DISS 1240 (male thread) (9/16 in - 18 thread)
- Male SIS
- 3/8 in British straight pipe thread

##### N<sub>2</sub>O Inlet:

- DISS 1040A (male thread) (7/8 in - 14 thread)
- Male SIS
- 3/8 in - 19 British straight pipe thread  
LH N<sub>2</sub>O

Mixed Gas Port: 5/16 in hose barb

Reservoir bag: 22mm outside diameter

### Weight

6 lbs. (2.72 kg)

### Delivery Flow Rate

O<sub>2</sub>: 1.0 - 9.9 LPM

N<sub>2</sub>O: 0 - 10 LPM

O<sub>2</sub> Flush: 10 - 30 LPM

20 LPM nominal at 50 psi input

### Gas Supply Pressure

O<sub>2</sub>: 50 - 73 psi (344.7 - 503.3 kPa)

N<sub>2</sub>O: 50 - 73 psi (344.7 - 503.3 kPa)

### Electrical

100 - 240 VAC ~ 0.5 AMP 50-60 Hz

Fuse  : T 2.5 AMP SLO-BLO 250 V

### Applied Parts Type

Type B

### Internal Power Supply Classification

Class I

### Environmental

#### Temperature

Storage/Transport: -10°F - 120°F  
(-23°C - 49°C)

Operational: 50°F -104°F (10°C - 40°C)

#### Relative Humidity

Storage/Transport (after use): 30-80%  
ambient and non-condensing

Operational: 30-80% ambient, non-  
condensing

## 2. Installation Instructions



**WARNING:** For centrally piped facilities, properly connected gas pipelines are essential to patient safety. The ultimate responsibility of assuring that lines are not crossed rests with the user. Per NFPA 99, the certified medical gas plumber, and verifier, should provide written documentation that all gas pipelines are connected properly and that all use points of the system have been tested prior to use. It is important that the user verify by their own test that all gas pipelines are connected properly prior to using the system.

### 2.1. Compatible Mounting Accessories

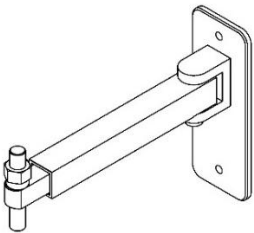
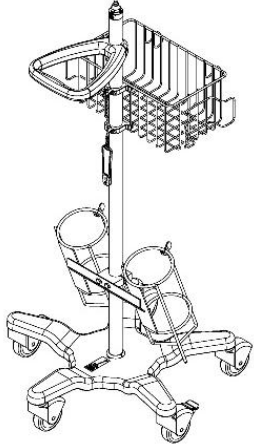
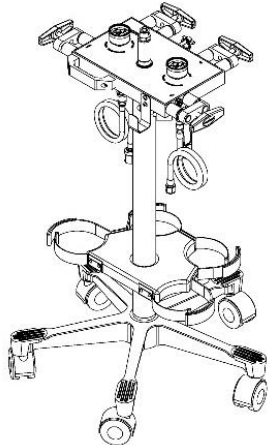
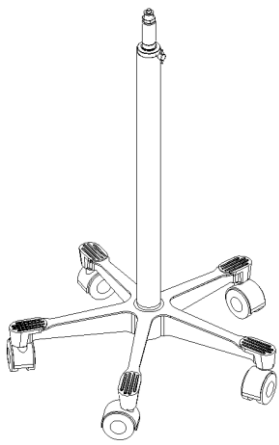
Wall Arm Mount	2-Cylinder Mobile Cart	E-Stand	Mobile Stand
	 <p><b>Note:</b> Basket maximum weight = 10 lbs (4.5 kg)</p>		

### 2.2. Mounting the Digital MDM Flowmeter

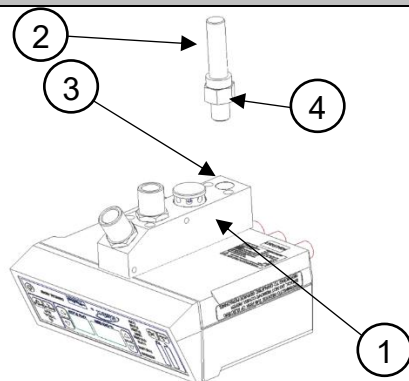
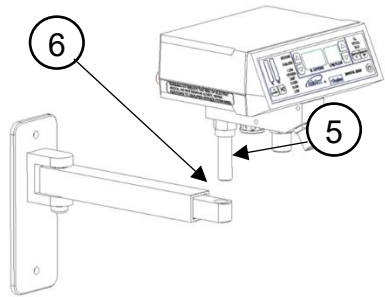
Wall Arm Mount	
<p><b>1</b> With the <b>Bag Tee</b> (1) attached to the Digital DMDM, thread the <b>mounting pin</b> (2) into mounting hole on <b>bottom of the Bag Tee</b> (3) until tight, then tighten <b>locking nut</b> (4) to secure pin.</p>	
<p><b>2</b> Lift the Digital MDM and place the <b>mounting pin</b> (5) into the <b>mounting hole</b> (6) on the top of the Wall Arm Mount.</p>	

## 2-Cylinder Mobile Cart, E-Stand, and Mobile Stand

<b>1</b>	Hold the Digital MDM Flowmeter so that the <b>mounting hole</b> (1) is above the <b>mounting thread</b> (2) of the Mounting Stand.	
<b>2</b>	Thread stud into 5/8 - 18 <b>threaded hole</b> (3) on bottom of the outlet housing until nut is reached.	
<b>3</b>	<b>Note:</b> If you are attaching to a 2-Cylinder Mobile Cart, take the extra step to tighten the set screw in the collar of the 2-Cylinder Mobile Cart to keep the flowmeter from rotating freely.	

### 2.3. Connecting Supply Lines



**WARNING:** Always use clean, dry, medical grade gases, and never oil or grease any part of the device.



**WARNING:** Do not change the connection fitting type or diameter of the supply hoses. The Diameter Indexed Safety System (DISS) is designed to prevent misconnection of N<sub>2</sub>O and O<sub>2</sub> supply lines.

## Gas Supply Line and Other Connections

<b>1</b>	Connect the power supply cable to the <b>power jack</b> (1).	
<b>2</b>	Connect the mixture hose from the bag tee to the <b>mixture fitting</b> (2) (if not already connected)	
<b>3</b>	Connect the N <sub>2</sub> O hose to the <b>N<sub>2</sub>O inlet</b> (3). Hand-tighten the hexagon fitting and then finish tightening with a 11/16 inch open end wrench (approximately 1/8 turn). Do not overtighten.	
<b>4</b>	If using optional Demand Valve Resuscitator for Emergency O <sub>2</sub> , connect the gas line to <b>O<sub>2</sub> outlet</b> (4). Hand tighten and then tighten 1/8 turn with 7/8 inch open end wrench. Do not overtighten.	
<b>5</b>	Connect the O <sub>2</sub> hose to the <b>O<sub>2</sub> inlet</b> (5). Hand-tighten the hexagon fitting and then finish tightening with a 7/8" inch open end wrench (approximately 1/8 turn). Do not over-tighten.	
<b>6</b>	Verify gas-tight connections and that there are no leaks at the connections.	

Optional Matrix Directional “Y” Valve Connection		
<b>1</b>	Verify that the sealing O-ring is in place. Place <b>directional “Y” valve adapter</b> (1) over the patient connector port of the Digital MDM Flowmeter. Ensure adapter is fully seated on connector.	
<b>2</b>	Attach <b>right angle adaptor</b> (2) to each of the <b>gas outlet connections</b> (3).	
<b>3</b>	Attach to one of the <b>right-angle adaptors</b> (1) to the <b>corrugated tubing</b> (2), <b>non-rebreathing valve</b> (3), and <b>full-face mask</b> (4). This is the full-face mask line.  Attach to the other right-angle adaptor the Matrix Breathing Circuit (not shown). This is the nasal hood line.	
<b>4</b>	The lever on the directional “Y” valve can be used to switch between the full-face mask line and nasal hood line.	

## 3. Instructions for Use

### 3.1. Setup and Prechecks



**WARNING:** To minimize the risk of fire or explosion:

- Always ensure cylinder valves are clear of dust and dirt prior to connection. One method to clear dust and dirt is to briefly “crack” the cylinder valve open to blow out any debris in the line before installing the cylinder.
- Do not discharge the gas at any person or flammable material.
- Always turn on Cylinder Valves slowly and fully.



**WARNING:** The user should observe the patient to prevent over sedation in the event of an O<sub>2</sub> failsafe malfunction or a crossed lines situation. If a patient becomes overly sedated when being delivered 100% O<sub>2</sub>, immediately remove the mask and encourage mouth breathing. This is an indication of a failsafe malfunction or crossed lines. In this case, only deliver pure O<sub>2</sub> from an independent source.

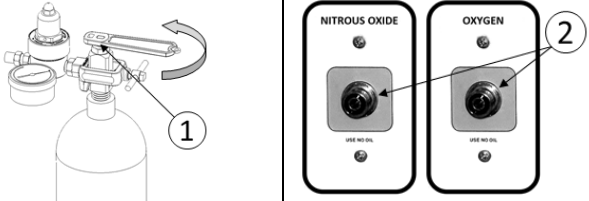

**CAUTION:** It is best practice upon completion of the procedure to close the cylinders (if portable gas supply) or disconnect from wall outlets (if central gas supply). Failure to do so may result in gas depletion should there be a leak.

1	Ensure the device is securely mounted (as described in <b>Section 2.2 Mounting the Digital MDM</b> ) and the gas supply hoses are connected to the correct fittings on the Digital MDM Flowmeter (as described in <b>Section 2.3 Connecting Supply Lines</b> ).	
2	Ensure the necessary prechecks have been performed, before using the Digital MDM Flowmeter. The precheck instructions are described in <b>Section 4.1 Prechecks</b> .	
3	Turn on the N <sub>2</sub> O and O <sub>2</sub> gas supplies. If using gas cylinders, slowly open the <b>cylinder valves</b> (1). If connecting to a wall supply, connect the supply lines to the appropriate <b>outlet connections</b> (2).	
4	When using a compatible portable mounting accessory, supply pressure is preset by the manufacturer. When using a wall supply, ensure supply pressure is within specification, 50-73 psi (344.7-503.3 kPa)	
5	Connect a compatible breathing circuit and breathing bag (as applicable).	

### 3.2 Operating Instructions



**WARNING:** To reduce the risk of electrical shock or electromagnetic interference:



- The unit must be grounded.
- Do not use a damaged electrical cord.
- Do not use the device with an extension cord.

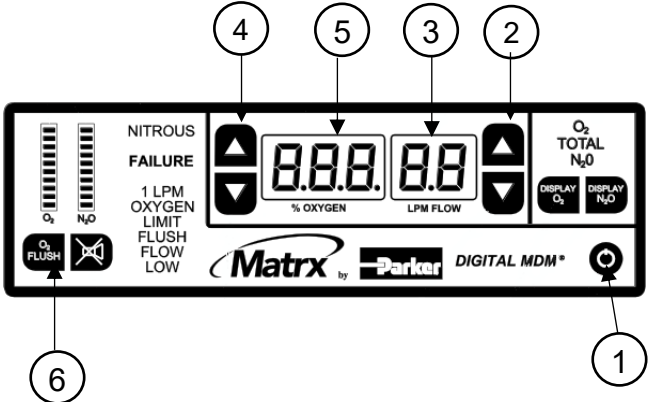

**WARNING:** Grounding Reliability can only be achieved when power supply is connected to an equivalent receptacle marked “Hospital ONLY” or “Hospital Grade”

1	Power device on using the <b>On/Off Button</b> (1)	
1	Press <b>Flow Control</b> ▲/▼ buttons (2) to set desired <b>flowrate</b> (3).	
2	Press <b>% O<sub>2</sub> Control</b> ▲/▼ buttons (4) to set desired <b>% O<sub>2</sub></b> (5). To lower observed patient level of conscious sedation, press <b>% O<sub>2</sub> Control</b> ▲ button to increase % O <sub>2</sub> .	
3	Before the procedure starts, if desired, press the <b>O<sub>2</sub> Flush Button</b> (6) to pre-fill the breathing bag (if connected) with 100% O <sub>2</sub> ensuring the patient's first breath is not from an empty breathing bag.	
4	Place breathing circuit nasal hood on patient and instruct the patient to inhale through the nasal hood. Patient should also be instructed to exhale through the nasal hood to achieve effective scavenging.	

<b>5</b>	When conditions call for the delivery of 100% O <sub>2</sub> : <b>a)</b> increase the % O <sub>2</sub> on the flowmeter to 100%. <b>b)</b> If using a directional Y valve, rotate the lever to full-face mask line. <b>c)</b> Control the desired flow of 100% O <sub>2</sub> through the <b>Flow Control ▲/▼ buttons</b> . <b>d)</b> Confirm delivery of 100% O <sub>2</sub> by monitoring patient condition.
<b>6</b>	If patient shows signs or communicates conditions of over-sedation, empty the breathing bag by squeezing it and then press and hold <b>O<sub>2</sub> Flush Button</b> to quickly fill the breathing bag with 100% O <sub>2</sub> .
<b>7</b>	At the completion of the procedure, remove the breathing circuit from the patient. Press <b>Flow Control ▼</b> button to achieve zero flow, then press the <b>On/Off Button (1)</b> to power the device off. Dispose of any single use items (such as nasal hood or breathing circuit).
<b>8</b>	Always turn O <sub>2</sub> and N <sub>2</sub> O cylinders valves off (for cylinder gas supply configurations) or disconnect the supply lines from the appropriate outlet stations (for pipeline gas supply configurations) to avoid unintentionally depleting source gases.

## 4. Maintenance

The Digital MDM Flowmeter have an expected lifetime of at least 15 years with proper maintenance. The Digital MDM Flowmeter require proper maintenance, pre-checks, and servicing. It is recommended to return the device to the manufacturer for servicing every 2 years. Following 15 years, the devices may need additional servicing and/or component replacement. A failed pre-check may require servicing from the manufacturer, please refer to Section 4.1.

For instructions on proper disposal of devices that are beyond their useful life, see section 4.5 of this document.

Check	Frequency
Inspect Digital MDM Flowmeter, hoses, fittings, and connections for damage, wear, and leaks.	Before every use
Machine Turn-On Test	Before every use
Alarm Indicator / Lamp Test	Before every use
O <sub>2</sub> Failure Test	Before every use
N <sub>2</sub> O Failure Test	Before every use
Indicated Flow Delivery Test	Before every use
Indicated Percentage (%) Delivery Test	Before every use
Non-Rebreathing Valve Test	Once a month
Emergency Air Intake Valve	Once a month
O <sub>2</sub> Flush Test	Once a month



**WARNING:** Proper inspection and maintenance of this device is essential to prevent gas leaks. All hoses, fittings, and connections should be inspected regularly, and all leaks should be repaired immediately.



**WARNING:** If precheck test cannot be executed successfully, do not use this device and contact distributor.



**WARNING:** Do not modify this equipment without authorization of the manufacturer.



**WARNING:** Do not use or replace any components or accessories, except those specified in these instructions for use and installation guide.

## 4.1. Pre-Check

**Note:** To perform these tests, gas supply cylinders or gas supply shutoff valves are required in order to isolate the gas supply from the device. Attempting to perform these tests with central pipeline supplied gas without a local shut off mechanism is not recommended.

### Machine Turn-On Test

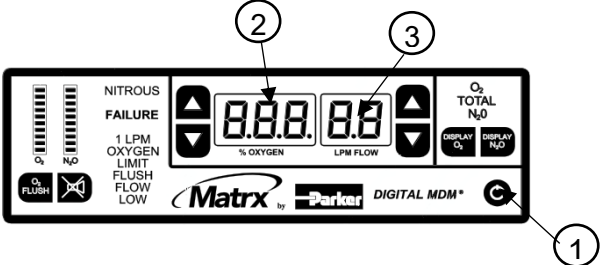
<p><b>1</b> Press the <b>ON/OFF</b> button (1) to turn the flowmeter on. After the flowmeter goes through an initialization routine, the <b>% O<sub>2</sub></b> (2) and <b>LPM Flow</b> (3) displays must display 100% and 5 LPM, respectively.</p>	
<p><b>2</b> If the displays do not show the correct information, contact your authorized distributor for service and troubleshooting.</p>	

### Alarm Indicator / Lamp Test

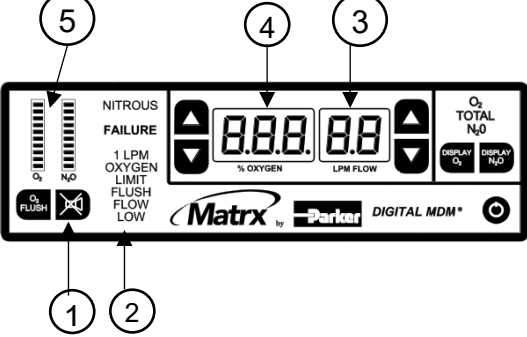
<p><b>1</b> Press <b>Alarm Test/Silence</b> button (1), and observe that all <b>alarm readouts</b> (2) illuminate. The <b>% O<sub>2</sub></b> (3) and <b>LPM Flow</b> (4) displays must also read 8.8.8. and 8.8, respectively</p>	
<p><b>2</b> The <b>alarm readouts</b> (2) must illuminate with numerical displays, 10 bars on the <b>Flow Indicators</b> (5) must illuminate for each gas, and the audible alert must sound.</p>	
<p><b>3</b> If the displays do not show the correct information or the alert does not sound, contact your authorized distributor for service and troubleshooting.</p>	

### O<sub>2</sub> Failure Test

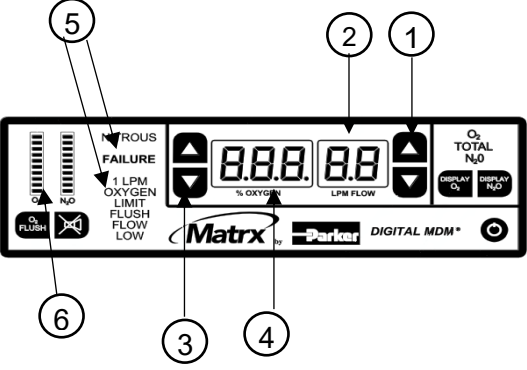
<p><b>1</b> Press <b>Flow Control</b> ▲/▼ buttons (1) to set <b>LPM Flow display</b> (2) to 9.9 LPM.</p>	
<p><b>2</b> Press <b>% O<sub>2</sub></b> ▲/▼ button (3) to set <b>% O<sub>2</sub> display</b> (4) to 50%.</p>	
<p><b>3</b> Turn off O<sub>2</sub> gas supply to the flowmeter.</p>	
<p><b>4</b> When the gas runs out, observe the following:</p> <ul style="list-style-type: none"> <li>• <b>O<sub>2</sub> Failure</b> alarm (5) illuminates</li> <li>• Audible alert sounds</li> <li>• <b>Flow Indicators</b> (6) are off</li> <li>• <b>LPM Flow</b> (2) and <b>% O<sub>2</sub></b> (4) displays are off</li> </ul>	
<p><b>5</b> Turn on O<sub>2</sub> gas supply. The flowmeter must return to normal operation. The alarm may continue to chime for up to 20 seconds after restoration of gas pressure.</p>	
<p><b>6</b> If the displays do not show the correct information or the alert does not sound, contact your authorized distributor for service and troubleshooting.</p>	

## N<sub>2</sub>O Failure Test

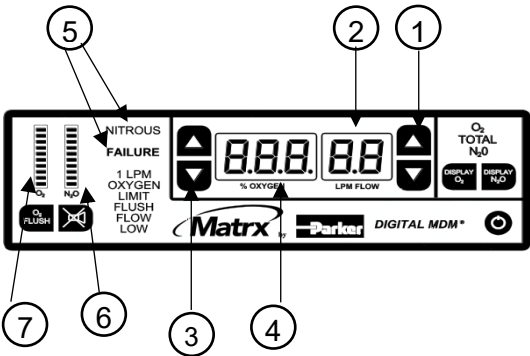
1	Press <b>Flow Control</b> ▲/▼ buttons (1) to set <b>LPM Flow display</b> (2) to 9.9 LPM.	
2	Press % O <sub>2</sub> ▲/▼ button (3) to set % O <sub>2</sub> <b>display</b> (4) to 30%.	
3	Turn off N <sub>2</sub> O gas supply to the flowmeter.	
4	<p>When the gas runs out, observe the following:</p> <ul style="list-style-type: none"> <li>• <b>N<sub>2</sub>O Failure</b> alarm (5) illuminates</li> <li>• Audible alert sounds</li> <li>• <b>LPM Flow display</b> (2) indicates O<sub>2</sub> being delivered,</li> <li>• the % O<sub>2</sub> display (4) and <b>N<sub>2</sub>O gas flow indicator</b> (6) are off,</li> <li>• <b>O<sub>2</sub> gas flow indicator</b> (7) shows at least 3 bars.</li> </ul>	
5	Turn on N <sub>2</sub> O gas supply. The unit must return to normal operation. The alarm may continue to chime for up to 20 seconds after restoration of gas pressure.	
6	If the displays do not show the correct information or the alert does not sound, contact your authorized distributor for service and troubleshooting.	

## Indicated Flow Delivery Test

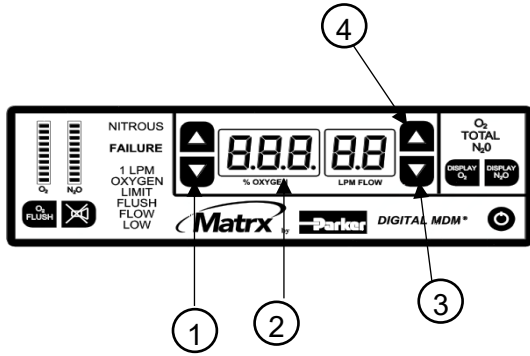
1	Press % O <sub>2</sub> Control ▲/▼ buttons (1) to set the % O <sub>2</sub> display (3) to 100%.	
2	Press and hold the <b>Flow Control</b> ▼ button (3) to decrease the flow rate to 1.0 LPM. An audible alert must sound at the lower limit while the button is held.	
3	Press and hold the <b>Flow Control</b> ▲ button (4) to increase the flow rate to 9.9 LPM. An audible alert must sound at the upper limit while the button is held.	
4	If the alert does not sound or fails to continuously sound while the buttons are held, contact your authorized distributor for service and troubleshooting.	

### Indicated Percentage (%) Delivery Test

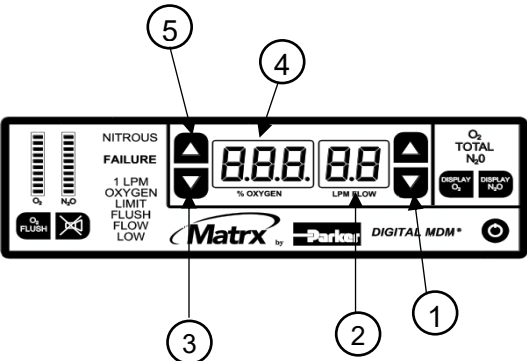
1	Press <b>Flow Control ▲/▼</b> buttons (1) to set the <b>LPM Flow display</b> (2) to 9.9 LPM.	
2	Press and hold the <b>% O<sub>2</sub> Control ▼</b> button (2) to decrease the <b>% O<sub>2</sub> display</b> (3) to 30%. The audible alert must sound at the lower limit while the button is held.	
3	Press and hold the <b>% O<sub>2</sub> Control ▲</b> (3) button to increase the <b>% O<sub>2</sub> display</b> (4) to 100%. An audible alert must sound at the upper limit while the button is held.	
4	If the alert does not sound or fails to continuously sound while the buttons are held, contact your authorized distributor for service and troubleshooting.	

### Non-Rebreathing Valve Test:

1	Turn the flowmeter off by pressing the <b>On/Off Button</b> .
2	Connect a breathing circuit to the bag tee. Disconnect the nasal hood from the rest of Breathing Circuit.
3	Blow into the inhalation line of the breathing circuit, the breathing bag should not inflate.
4	If breathing bag inflates, contact your authorized distributor for service and troubleshooting.

### Emergency Air Intake Valve Test:

1	Turn the flowmeter off by pressing the <b>On/Off Button</b> .
2	Connect a breathing circuit to the bag tee. Disconnect the nasal hood from the rest of breathing circuit.
3	Remove the breathing bag from the bag tee and create a seal by placing hand over the bag port on the bag tee.
4	Inhale through the breathing circuit. Air intake valve should open allowing you to breath in room air.
5	If you can not breathing in room air, contact your authorized distributor for service and troubleshooting.

### O<sub>2</sub> Flush Test:

1	Press and hold <b>O<sub>2</sub> Flush Button</b> .
2	Observe that the breathing bag quickly inflates.
3	If the breathing bag does not inflate quickly, contact your authorized distributor for service and troubleshooting.

## 4.2. Fuse Replacement

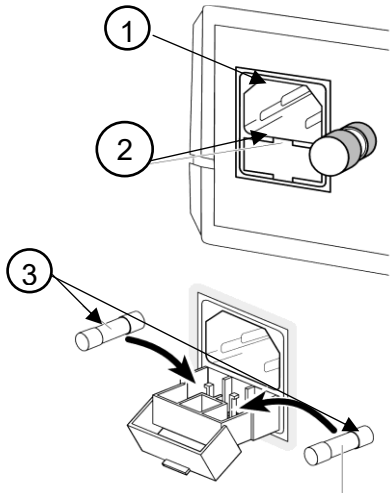
1	Turn flowmeter off by pressing <b>On/Off Button</b> .	
2	Unplug the power cord to the flowmeter from wall.	
3	Remove power supply cable from <b>power jack</b> (1).	
4	Open the <b>fuse compartment</b> (2)	
5	Two fuses are required for the unit to operate. Remove each <b>fuse</b> (3) from its clip and replace it with a fuse that meets the specifications listed in <b>Section 1.9 Specifications</b> .	

## 4.3. Cleaning

The Digital MDM Flowmeter must be cleaned between each use in order to prevent the spread of infections. Cleaning the device has been validated with Super Sani-Cloth™ Germicidal wipes.

**WARNING:** The following warning applies to the device and any device's components and accessories:



- Do not spray directly with disinfecting chemicals.
- Do not immerse in water, sanitizer, cleaning solution, or any other liquid.
- Do not sanitize or wipe the inside of the fittings, gas supply hoses, or connection ports.
- Always ensure the device and device's components and accessories are completely dry before use.

1	Disconnect and dispose of any single use breathing circuit and/or single use nasal hood (if attached). For cleaning instructions of re-useable breathing circuit and/or nasal hood refer to breathing circuit Instructions for Use.
2	Using a Super Sani-Cloth™ Germicidal wipe, thoroughly wipe down the Digital MDM Flowmeter until all visible dirt and soil is removed. Take extra care to wipe the touch control buttons as these are the most handled areas of the device. A soft bristled brush may be used to loosen any soil that is difficult to remove.
3	Using a Super Sani-Cloth™ Germicidal wipe, thoroughly wipe down the gas supply hoses and fittings until all visible dirt and soil is removed. Do not wipe the inside of the hoses or fittings as this may deposit cleaning agents into the breathing pathway of the device.
4	The <b>bag port</b> , <b>breathing circuit port</b> , and <b>emergency air intake valve</b> should not be exposed to the cleaners or wiped to prevent moisture from entering the device. Avoid wiping and applying cleaner to the inside of the ports and the valve.

## 4.4. Troubleshooting: Error Codes

Error Code	Definition	Resolution
EE01	EEPROM Cannot be read	<ol style="list-style-type: none"> <li>1. Reset the DMDM by turning off and on.</li> <li>2. If error remains, discontinue use and contact distributor.</li> </ol>
EE02	N <sub>2</sub> O is leaking	<ol style="list-style-type: none"> <li>1. Ensure connections on back panel are secure.</li> <li>2. Reset the DMDM by turning off and on.</li> <li>3. If error remains, discontinue use and contact distributor.</li> </ol>
EE03	O <sub>2</sub> is leaking	<ol style="list-style-type: none"> <li>1. Ensure connections on back panel are secure.</li> <li>2. Reset the DMDM by turning off and on.</li> <li>3. If error remains, discontinue use and contact distributor.</li> </ol>
EE04	Cannot read NOVRAM	<ol style="list-style-type: none"> <li>1. Reset the DMDM by turning off and on.</li> <li>2. If error remains, discontinue use and contact distributor.</li> </ol>
EE05	N <sub>2</sub> O flow out of limit	<ol style="list-style-type: none"> <li>1. Reduce N<sub>2</sub>O flow.</li> </ol>
EE06	O <sub>2</sub> flow out of limit	<ol style="list-style-type: none"> <li>1. Reduce O<sub>2</sub> Flow</li> </ol>
EE07	N <sub>2</sub> O flow absent or transducer malfunction	<ol style="list-style-type: none"> <li>1. Confirmed N<sub>2</sub>O gas supply is turned on.</li> <li>2. If gas supply is on and error remains, discontinue use and contact distributor.</li> </ol>
EE08	O <sub>2</sub> flow absent or transducer malfunction	<ol style="list-style-type: none"> <li>1. Confirmed O<sub>2</sub> gas supply is turned on.</li> <li>2. If gas supply is on and error remains, discontinue use and contact distributor.</li> </ol>
EE09	N <sub>2</sub> O Valve is over pressurized and leaking	<ol style="list-style-type: none"> <li>1. Confirm 50-73 PSIG N<sub>2</sub>O supply pressure</li> </ol>
EE10	O <sub>2</sub> Valve is over pressurized and leaking	<ol style="list-style-type: none"> <li>1. Confirm 50-73 PSIG O<sub>2</sub> supply pressure</li> </ol>

## 4.5. Disposal



It is best practice to inquire with local authorities for proper disposal guidelines, if applicable.

## 5. Material Residual Risks









The device contains lead, cobalt, nickel, hexavalent chromium, chloroprene, and nickel hydroxide which were identified as CMR/EDC and believed to exceed the 0.1% weight-by-weight threshold requirements of REACH and Section 10.4 of the EU MDR 2017/745.











The residual risks posed by the presence of these substances in the device are low and do not impact the overall safe use of the device. No measures need to be taken by the end user to ensure patient safety regarding use of the device containing these substances.



The potential for exposure to these substances are limited to contact of gases with alloy components (such as aluminum and brass) containing these substances. Patient exposure requires that the substances produce volatile organic compounds, aldehydes, or particulate matter. Extensive biocompatibility testing has been conducted that has demonstrated the use of the materials of construction are unlikely to result in a toxicological effect. In addition, patient exposure is considered to be limited duration given the infrequent use and application intervals that are expected to be long relative to the elimination time of any leachable toxins from the body.

## 6. Symbols Glossary

The following symbols may be used throughout this document, as well as on device labels and packaging.

Symbol	Title of Symbol	Description of Symbol
	<b>Manufacturer Information</b>	Indicates the medical device manufacturer and is accompanied by the name and address of the manufacturer. [EN ISO 15223-1:2021, clause 5.1.1]
	<b>Date of manufacture and Country of Manufacture</b>	Indicates the country where the device was manufactured. Also Indicates the date when the device was manufactured. This symbol is accompanied by four digits for the year the device was manufactured. [EN ISO 15223-1:2021, clause 5.1.3, 5.1.11]
	<b>Catalog Number</b>	Indicates the manufacturer's catalog number of the device and is used for identification of the device. [EN ISO 15223-1:2021, clause 5.1.6]
	<b>Serial Number</b>	Indicates the manufacturer's serial number of the device and is used for identification of the specific device. [EN ISO 15223-1:2021, clause 5.1.7]
	<b>Unique device identifier</b>	Indicates a carrier that contains unique device identifier information [EN ISO 15223-1:2021, clause 5.7.10]
	<b>Prescription device</b>	Indicates that federal law restricts this device to sale by or on the order of a physician or dentist.
	<b>Medical Device</b>	Indicates the item is a medical device [EN ISO 15223-1:2021, clause 5.7.7]
	<b>Use-by date</b>	Indicates the date after which the medical device is not to be used [EN ISO 15223-1:2021, clause 5.1.4]
	<b>Consult Instructions for Use</b>	Indicates the need for the user to consult the instructions for use [EN ISO 15223-1:2021, clause 5.4.3]

Symbol	Title of Symbol	Description of Symbol
	<b>Caution</b>	Indicates the need for the user to consult the instructions for use for important cautionary information such as warnings and precautions that cannot be presented on the medical device itself. [EN ISO 15223-1:2021, clause 5.4.4]
	<b>Caution/Warning</b>	Indicates important cautionary or warning information to the user that is presented in the instructions for use that accompanies explanatory instructions to the user
	<b>European Community Authorized Representative</b>	Indicates the authorized representative in the European Community (European Union) [EN ISO 15223-1:2021, clause 5.1.2]
	<b>Switzerland Authorized Representative</b>	Indicates the authorized representative in Switzerland [MU600_00_016e / V3.0]
	<b>Conformité Européenne (CE) Mark</b>	Indicates that the product may be traded freely in any part of the European Economic Area, regardless of its country of origin. [2017/745 EU Annex V]
	<b>Protective Conductor Terminal</b>	Indicates that the product includes a terminal bonded to conductive parts for safety purposes and is intended to be connected to an external protective earthing system. [IEC60601-1: 2006 +A2:2021, clause 3.95, Symbol table D1 number 6 (Symbol also IEC60417-5019)]
	<b>Disposal of WEEE</b>	Indicates that the device may require separate municipal waste collection. [2012/19 EU, Article 14(4) Annex IX (Symbol also IEC60417-6414)]
	<b>Equipotentiality</b>	Indicates the terminals which, when connected together, bring various parts of an equipment or of a system to the same potential. [IEC60601-1: 2006 +A2:2021, Symbol table D1 number 8]
	<b>Contains Hazardous Substances</b>	Indicates a medical device that contains substances that can be carcinogenic, mutagenic, reprotoxic (CMR) or substances with endocrine disrupting properties. [ISO 15223-1, Clause 5.4.10]
	<b>Follow Instructions for Use</b>	Indicates when the user should refer to the instructions for use manual/booklet for important information [ISO 60601-1, Table D.2, No. 10]

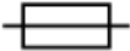
Symbol	Title of Symbol	Description of Symbol
	<b>Type B Applied Part</b>	Indicate a medical device has a type B applied part (Connection for Fresh Gas Tubing and Emergency O <sub>2</sub> /O <sub>2</sub> Outlet Connections) <small>[IEC 60601-1, Table D.1, No. 19]</small>
	<b>Alternating current (AC)</b>	Indicates that the instrument is set to measure AC quantities. <small>[IEC 60601-1, Table D.1, No. 1]</small>
	<b>Fuse</b>	Identify fuse boxes or their location <small>[IEC 60417-1]</small>

# 7. Warranty

## CERTIFICATE OF WARRANTY

THIS WARRANTY IS GIVEN IN PLACE OF ALL OTHER WARRANTIES, EXPRESS OR IMPLIED, OF MERCHANTABILITY, FITNESS FOR A PARTICULAR PURPOSE OR OTHERWISE.

Under no circumstances shall Parker Hannifin Corporation be liable for incidental or consequential damages as those terms are defined in the uniform commercial code.

Parker Hannifin Corporation, Porter Instrument warrants that each product or part shall be free from defects in workmanship and materials, under normal use and with appropriate maintenance, for one (1) year from the date of delivery to customer unless otherwise specified in writing. All rubber and plastic parts and accessories are warranted under the same conditions for a period of ninety (90) days from date of purchase.

No statement or claim about the product by any employee, agent, representative, or dealer of Parker Hannifin Corporation shall constitute a warranty by Parker Hannifin Corporation or give to rise to any liability or obligation of Parker Hannifin Corporation.

Parker Hannifin Corporation shall not be liable for any damage, injury or loss arising out of the use of the product, whether as a result of a defect in the product or otherwise, if, prior to such damage, injury or loss, the product was (1) damaged or misused; (2) repaired, altered or modified by persons other than Parker Hannifin Corporation; (3) not installed in strict compliance with applicable codes and ordinances; or (4) not installed by an authorized Parker Hannifin Corporation dealer. Parker Hannifin Corporation's obligation for breach of this warranty, or for negligence or otherwise, shall be strictly and exclusively limited to the repair or replacement of the product or part. This warranty shall be void on any product on which the serial number has been altered, defaced or removed.

**ORDERS** All orders are to be made through authorized Parker Hannifin Corporation distributors. All billing will be done through said distributors. Direct orders will be handled through the authorized local dealer as determined by Parker Hannifin Corporation.

**RETURNS** All returned merchandise will be handled through the local Parker Hannifin Corporation distributor. No returns will be accepted unless authorized in writing by Parker Hannifin Corporation and accompanied by the original shipping invoice. All returns are subject to restocking charge.

Policies subject to change without notice.

To register your product: visit <https://www.porterinstrument.com/dental-support> and click on Warranty Registration Form button.