**INSTALLATION
AND
OPERATING
INSTRUCTIONS**

**COMPACT TRIPLE
CABINET OUTLET
STATION
MODEL 6258-1B**

PORTER INSTRUMENT COMPANY, INC.

245 TOWNSHIP LINE RD. P.O. BOX 907 HATFIELD, PA 19440-0907 USA [215] 723-4000 / FAX [215] 723-2199

Compact Triple Cabinet Outlet Station Model 6258-1B Installation and Operating Instructions

The Porter Compact Triple Cabinet Outlet Station (6258-1B) provides a quick, safe, and reliable method of connection to both Porter Sedation and Clean-Air™ outlet service in a cabinet mount configuration. The 6258-1B provides all the service features of the Porter 6200-1 N₂O/O₂ outlet station, and the Porter 5600-3 Clean-Air outlet station. Features include the **cross+protection** system to prevent unintentional misconnection to the central piping system. A qualified plumber can install the outlet station by following the details listed in this brochure.



WARNING

Porter Instrument Company, Inc. Outlet Stations utilize the **cross+protection** system. The flexible hose and connectors used with the Compact Triple Outlet to connect with the central gas piping system are diameter indexed. The **cross+protection** system is designed to prevent misconnection of Oxygen and Nitrous Oxide piping. **DO NOT ATTEMPT TO CHANGE THE DIAMETERS OR THE CONNECTION CONFIGURATION OF THE SEDATION COUPLERS TO THE OUTLET STATION BLOCK!** Tampering with the **cross+protection** system constitutes acceptance of liability by the installer. For your own protection, as well as that of the Doctor and the patients, use 3/8" O.D. tubing for all Nitrous Oxide lines and 1/2" O.D. tubing for all Oxygen lines. The vacuum line fitting into the outlet station block is non-interchangeable with the Oxygen fitting, but is field removable for installation flexibility. The sedation couplers are permanently attached to the outlet station block.

To assure safe operation and conformation to local fire codes, all Porter Instrument Company Outlet Stations are designed to be used with sedation delivery systems mounted inside walls that meet or exceed the guidelines established by the National Fire Protection Association for Nonflammable Medical Gas Systems, NFPA 99. The Compact Triple Cabinet Outlet Station is designed to be mounted **INSIDE A CABINET ONLY (IN THE SUB-BASE / TOE PLATE AREA)**, AND AS SUCH, USES FLEXIBLE HOSE. IF AN INSIDE WALL OR WALL ATTACHMENT MOUNTING IS REQUIRED, YOU MUST USE THE STANDARD PORTER TRIPLE OUTLET STATION. Copies of NFPA 99 or portions thereof may be obtained by writing to:

National Fire Protection Association
Batterymarch Park
Quincy, MA 02269-9904
Or call: 1-800-344-3555

 **WARNING**

Dental workers are exposed to N₂O during administration of N₂O/O₂ conscious sedation analgesia. NIOSH has recommended that exposures should be minimized. Contact NIOSH (1-800-35-NIOSH) to receive NIOSH Publications on *Control of Nitrous Oxide in Dental Operatories*. Exposure can be minimized by effective controls. National Institute for Occupational Safety and Health (NIOSH) publications state that controls, including System Maintenance, Ventilation and Work Practices can effectively reduce N₂O concentrations in dental operations. Your Porter Scavenger System is an important part of the system of controls.

STATION INSTALLATION INSTRUCTIONS

1. Select an appropriate location **in the sub-base front / toe plate on the cabinet (not intended for wall mounting)**. Making sure to center the opening in the height of the sub-base (see Figure 1), cut out the kick plate on the sub-base using the supplied template (see Figure 2 on back page). Secure the station block using the factory brackets. The brackets can be adjusted for mounting to the rear or through the front of the toe plate. Connections extend out the rear of the unit.
2. The station is designed to be used with sedation lines that end in DISS (Diameter Index Safety System) couplers.
3. The sedation connections extending out the back of the station block are **cross+protection** system diameter indexed and are permanently attached to the block. **DO NOT REMOVE THE OXYGEN AND NITROUS OXIDE NPT FITTINGS.**
4. The vacuum connection to the station block is tightened into a 1/4" NPT block hole. The vacuum line fitting shipped with the station is non-interchangeable with the Oxygen sedation NPT block hole. For installation flexibility, the vacuum line fitting may be field removed and replaced with another appropriate fitting and line to attach to the HVE High Volume Evacuation line.
5. After connecting all gas lines and the flexible hoses to the sedation lines of the station block, check the system for leaks with the intended service gas (N₂O/O₂) per NFPA 99 4-5.4.1.3. (static pressure test). This is a 50 PSI test for pressure decay for 24 hours; 5 PSI drop allowed.
6. Check for crossed lines.

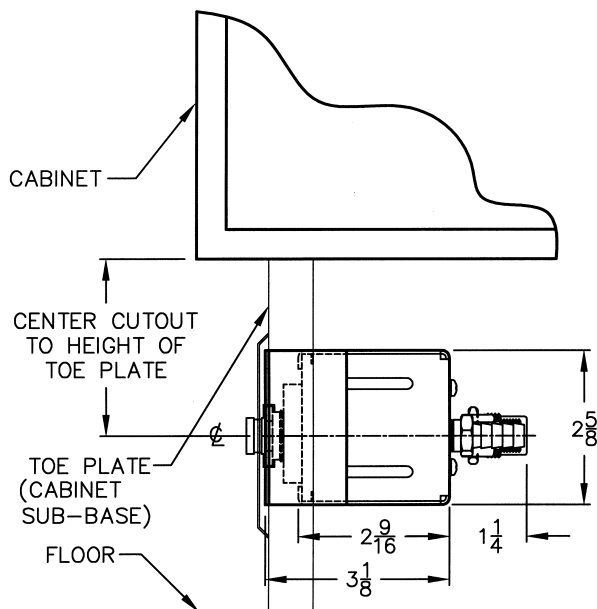

FIGURE 1

Refer to NFPA Gas and Vacuum Systems Code for Type III Systems. (See **cross+protection Warning** in this brochure.)

7. Alignment and Adjustment for Front Plate Installation – The Oxygen and Nitrous Oxide Valve Bodies are factory adjusted to allow for the back of the front cover plate to press against the metal surfaces of all three valve bodies. If adjustment is needed, follow these steps:

7.1. Rotate the Oxygen and Nitrous Oxide valve bodies so they contact the back of the Front Plate. Oxygen has right hand threads and Nitrous Oxide has left hand threads.

7.2. Adjust the right hand thread vacuum valve body to align with the metal surfaces of the other valve bodies.

7.3. The two sedation valve bodies should be in alignment and touching the Front Plate extruded holes, and the vacuum valve body should be slightly higher and should be pressing against the flat part of the Front Plate when it is installed with the six flat head screws.

8. Apply diameter indexed N₂O/O₂ gas labels and vacuum label in place over diameter indexed check valve connector bushings. Pull off center strip backing, and press label in place. Remove top and bottom backing strips, and finish securing label.

9. Re-attach the sedation couplers and flexible hose.

10. Connect an 8060 series duplex connector and hoses into the completely assembled Compact Triple Outlet Station. Attach the other end of the hoses to a flowmeter and turn the flow control knobs to the off position and the on/off switch to the off position.

11. **Leak test the entire system for working pressure leaks.** Pressurize the sedation gas supply lines with 50 PSI in a similar manner as was done during the Step 6, 50 PSI NFPA static pressure test. Observe any pressure decay after 12 hours. This 50 PSI test with the flowmeter tubing connections in place tests the seal of the duplex connector extended into the o-rings of the outlet station primary check valves. (5 PSI drop allowed.)

12. Attach the appropriate vacuum lines to the station vacuum line.

CONNECTIONS TO FLOWMETER OPERATING INSTRUCTIONS

Flowmeter Gas Supply Tubing and Vacuum Tubing is connected to the Compact Triple Outlet Station via two quick connect couplers. The Porter 8060 series duplex connector simultaneously connects the Oxygen and Nitrous Oxide tubing, and prevents the Nitrous Oxide from being connected unless the Oxygen is connected. The Porter 5602 vacuum quick connect with hose barb separately inserts into the vacuum check valve of the station.

Quick Connecting: You may quick connect to the station when the system pressure is at its normal 50 PSI; the primary check valves seal this pressure. Both couplers have locating latches. Simply insert the couplers into the appropriate check valve and confirm the latch is in place behind the catch feature of the valve. A gentle tug on the coupler will confirm a stable latch position. To remove, slide the latch out of position.

Resuscitator: Remove the duplex connector so a resuscitator quick connect may be inserted into the oxygen station position.

Reverse position for 5602 right angle vacuum quick connect hose barb:

Reconfigure the fitting using the following steps if you need the barb to point in the opposite direction.

Clip Reversal Instructions:

1. Note orientation of Clip on Assembly: Hold assembly with Hose Barb in the down position, and with the smooth post facing you.
 - 1.1. Note the position of the clip on the assembly. This is important, as you will need to rotate the clip 180° from its original position.
2. Remove the Crescent Ring using the blade of a small flat blade screwdriver.
3. Lift the clip from the assembly, and as you do so, the spring will fall from the clip.
4. Slide the clip back onto the assembly in a position 180° from its original location.
5. As the clip is brought down onto the post, place the spring onto the pin (located on the clip), and tuck the opposite end into the pocket on the adapter body.
6. Again using a flat bladed screwdriver, push the Crescent Ring back into the groove on the post. Orient the Crescent Ring such that the opening in the ring faces away from the spring.
7. Actuate clip to ensure proper operation of the assembly.

MAINTENANCE AND SERVICE

Use scavenging. Monitor for N₂O in the operatory to insure that controls are effective in achieving low levels of ppm (parts per million) exposure. Contact your Porter dealer for details on monitors and testing.

Inspect and maintain the analgesia delivery system to prevent N₂O leaks in all hoses, connections and fittings. Repair all leaks immediately.

MONTHLY CHECK: Leak test the entire system for working pressure leaks.

1. Connect an 8060 series duplex connector and hoses into the Compact Triple Outlet Station.
2. Attach the other end of the hoses to a flowmeter and turn the flow control knobs to the off position and the on/off switch to the off position.
3. Pressurize the sedation gas supply lines with 50 PSI, then close the gas supply tank valves.
4. Observe any pressure decay after 12 hours. This 50 PSI test with the flowmeter tubing connections in place tests the seal of the duplex connector extended into the o-rings of the outlet station primary check valves. (5 PSI drop allowed.)

Service Primary and Secondary Check Valve Assemblies

The Oxygen and Nitrous Oxide primary and secondary check valve assemblies may be field disassembled and replaced.

Service Primary Check Valve – May be serviced with station pressurized to 50 PSI.

1. Remove front plate. Mounting screws are behind plate labels.
2. Unscrew the primary check valve assembly. Oxygen right hand threads; Nitrous Oxide left hand threads. **Note: the secondary check valve will move into position and seal the 50 PSI of the station pressure as the primary check valve assembly is removed.**



WARNING

Do not remove the cartridge body while servicing the primary check valve assembly. The secondary check valve cannot seal the 50 PSI pressure if the cartridge body is removed.

3. Replace the entire assembly.
4. Screw the replaced assembly into the cartridge body.
5. Alignment and Adjustment for Front Plate Installation – The Oxygen and Nitrous Oxide Valve Bodies are factory adjusted to allow for the back of the front cover plate to press against the metal surfaces of all three valve bodies. If adjustment is needed, follow these steps:

5.1. Rotate the Oxygen and Nitrous Oxide valve bodies so they contact the back of the Front Plate. Oxygen has right hand threads and Nitrous Oxide has left hand threads.

5.2. Adjust the right hand thread vacuum valve body to align with the metal surfaces of the other valve bodies.

5.3. The two sedation valve bodies should be in alignment and touching the Front Plate extruded holes, and the vacuum valve body should be slightly higher and should be pressing against the flat part of the Front Plate when it is installed with the six flat head screws.

6. **Leak test the entire system for working pressure leaks per the Monthly Check.**

Service Secondary Check Valve



WARNING

To service the secondary check valve, first turn off pressure. Do not remove the cartridge body until the pressure is bled off. The secondary check valve cannot seal the 50 PSI pressure if the cartridge body is removed.

1. **Turn off pressure at tanks in tank room.**
2. Follow procedure to remove primary check valve assembly.
3. Depress secondary check valve further into station block using a small probe or screw driver to bleed off pressure.
4. Unscrew cartridge body out of the station block.
5. Take a small screw driver or needle nose pliers and insert into holes at the center of secondary check valve. Carefully remove check valve and spring.
6. Replace the 016 o-ring and secondary check valve parts as required and place in position for reassembly.
7. Screw in the cartridge body and tighten.
8. Screw in the primary check valve assembly and align and adjust for front plate installation.
9. **Leak test the entire system for working pressure leaks per the Monthly Check.**

WARRANTY

THIS WARRANTY IS GIVEN IN PLACE OF ALL OTHER WARRANTIES, EXPRESS OR IMPLIED, OF MERCHANTABILITY, FITNESS FOR A PARTICULAR PURPOSE OR OTHERWISE.

Under no circumstances shall Porter Instrument Company, Inc. be liable for incidental or consequential damages as those terms are defined in the uniform commercial code.

Porter Instrument Company, Inc. warrants that each product or part shall be free from defects in workmanship and materials, under normal use and with appropriate maintenance, for one (1) year from the date of delivery to customer unless otherwise specified in writing. All rubber and plastic parts and accessories are warranted under the same conditions for a period of ninety (90) days from date of purchase.

No statement or claim about the product by any employee, agent, representative, or dealer of Porter Instrument Company, Inc. shall constitute a warranty by Porter Instrument Company, Inc. or give rise to any liability or obligation of Porter Instrument Company, Inc.

Porter Instrument Company, Inc. shall not be liable for any damage, injury or loss arising out of the use of the product, whether as a result of a defect in the product or otherwise, if, prior to such damage, injury or loss, the product was (1) damaged or misused; (2) repaired, altered or modified by persons other than Porter Instrument Company, Inc.; (3) not installed in strict compliance with applicable codes and ordinances; or (4) not installed by an authorized Porter Instrument Company, Inc. dealer. Porter Instrument Company, Inc.'s obligation for breach of this warranty, or for negligence or otherwise, shall be strictly and exclusively limited to the repair or replacement of the product or part. This warranty shall be void on any product on which the serial number has been altered, defaced or removed.

ORDERS All orders are to be made through authorized Porter Instrument Company, Inc. distributors. All billing will be done through said distributors. Direct orders will be handled through the authorized local dealer as determined by Porter Instrument Company, Inc.

RETURNS All returned merchandise will be handled through the local Porter Instrument Company, Inc. distributor. No returns will be accepted unless authorized in writing by Porter Instrument Company, Inc. and accompanied by the original shipping invoice. All returns are subject to restocking charge.

Policies subject to change without notice.

FIGURE 2

6258-1B TEMPLATE CUT-OUT FOR KICK PLATE ON SUB-BASE

