

# INSTALLATION INSTRUCTIONS

---

---

## MODEL 6200K CHECK VALVE REPAIR KIT

## INSTALLATION INSTRUCTIONS

### 6200K CHECK VALVE REPAIR KIT

**Note:** This kit is for service of the primary check valve assembly only. Contact your dealer for repairs of the secondary check valve assembly. *The Oxygen and Nitrous Oxide primary check valve assemblies may be removed and replaced with a new assembly.*

---

**Service Primary check valve – May be serviced with station pressurized to 50 PSI. May also be serviced with pressure off at the gas cylinder tanks in the tank room.**

1. Remove front plate.
2. Unscrew the primary check valve assembly. Oxygen right hand threads; Nitrous Oxide left hand threads.

**Note:** the secondary check valve will move into position and seal the 50 PSI of the station pressure as the primary check valve assembly is removed.

 **WARNING**

Do not remove the cartridge body while servicing the primary check valve assembly. The secondary check valve cannot seal the 50 PSI pressure if the cartridge body is removed.

3. Replace the entire assembly.
4. Screw the replaced assembly into the cartridge body.
5. Alignment and Adjustment for Front Cover Plate Installation – The Oxygen and Nitrous Oxide Valve Bodies are designed to allow for the back of the Front Plate to press against the metal surfaces of both valve bodies. If adjustment is needed:

Rotate the Oxygen and Nitrous Oxide valve bodies so they both uniformly contact the back of the Front Plate when it is installed. Oxygen has right hand threads and Nitrous Oxide has left hand threads.

6. Leak test the entire system for working pressure leaks per the Monthly Check.

**Service Secondary check valve – contact dealer.**

 **WARNING**

To service the secondary check valve, first turn off pressure. Do not remove the cartridge body until the pressure is bled off. The secondary check valve cannot seal the 50 PSI pressure if the cartridge body is removed.

**Parts:**

- 1) Primary Check Valve Assembly  
O<sub>2</sub> A-1655-A; N<sub>2</sub>O A-1655-B

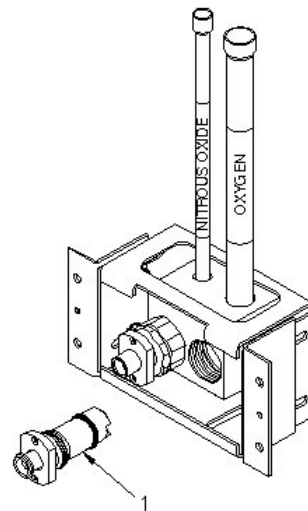

## MAINTENANCE AND SERVICE

**Use scavenging.** Monitor for N<sub>2</sub>O in the operatory to insure that controls are effective in achieving low levels of ppm (parts per million) exposure. Contact your Porter dealer for details on monitors and testing.

**Inspect and maintain** the analgesia delivery system to prevent N<sub>2</sub>O leaks in all hoses, connections and fittings. Repair all leaks immediately.

### **MONTHLY CHECK: Leak test the entire system for working pressure leaks.**

Connect an 8060 series duplex connector and hoses into the Outlet Station. Attach the other end of the hoses to a flowmeter and turn the flow control knobs to the off position and the on/off switch to the off position.

Pressurize the sedation gas supply lines with 50 PSI. Observe any pressure decay after 12 hours. This 50 PSI test with the flowmeter tubing connections in place tests the seal of the duplex connector extended into the o-rings of the outlet station primary check valves. (5 PSI drop allowed.)

## CONNECTIONS TO FLOWMETER OPERATING INSTRUCTIONS

Flowmeter Gas Supply Tubing is connected to the Outlet Station via a quick connect coupler. The Porter 8060 series duplex connector simultaneously connects the Oxygen and Nitrous Oxide tubing, and prevents the Nitrous Oxide from being connected unless the Oxygen is connected.

### **QUICK CONNECTING**

You may quick connect to the station when the system pressure is at its normal 50 PSI; the primary check valves seal this pressure. The coupler has a locating latch. Simply insert the coupler into the appropriate check valve and confirm the latch is in place behind the catch feature of the valve. A gentle tug on the coupler will confirm a stable latch position. Internally, within the primary check valve, an o-ring seals against a poppet. The same o-ring seals against the quick connect extensions upon insertion. Slide the latch out of position to remove the connector and the internal poppet will automatically move back into its sealing position.

### **RESUSCITATOR**

Remove the duplex connector so a resuscitator quick connect may be inserted into the Oxygen station position.



### **WARNING**

Dental workers are exposed to N<sub>2</sub>O during administration of N<sub>2</sub>O / O<sub>2</sub> conscious sedation analgesia. NIOSH has recommended that exposures should be minimized. Contact NIOSH (1-800-35-NIOSH) to receive NIOSH Publications on *Control of Nitrous Oxide in Dental Operatories*. Exposure can be minimized by effective controls. National Institute for Occupational Safety and Health (NIOSH) publications state that controls, including System Maintenance, Ventilation and Work Practices can effectively reduce N<sub>2</sub>O concentrations in dental operations. Your Porter Scavenger System is an important part of the system of controls.