

Nitrogen Manifold System INSTALLATION

MODEL 8200

***NOTICE: READ MANUAL
COMPLETELY BEFORE INSTALLING
AND OPERATING THIS DEVICE***

PORTER INSTRUMENT COMPANY, INC.

245 TOWNSHIP LINE RD. P.O. BOX 907 HATFIELD, PA 19440-0907 USA [215] 723-4000 / FAX [215] 723-2199

WARNING



PORTER INSTRUMENT COMPANY, INC. NITROGEN MANIFOLD SYSTEM, Hoses, and Outlet Stations utilize diameter indexed (DISS) fittings which are designed to be specific for Nitrogen. **DO NOT ATTEMPT TO CHANGE DIAMETERS!!** Tampering with fittings on the hoses constitutes acceptance of liability by the installer. For your own protection, as well as that of the Doctor and his patients, use **3/8" O.D.** tubing for all Nitrogen lines.

To assure safe operation and conformation to local fire codes, all Porter Instrument Company Nitrogen Manifold Systems meet or exceed the guidelines established by the National Fire Protection Association (NFPA) for Non-Flammable Medical Gas Systems, Type II, Level III, NFPA 99. Copies of NFPA 99 or portions thereof may be obtained by writing to: National Fire Protection Association, Batterymarch Park, Quincy, MA 02269-9904 or call : 1-800-344-3555

Type II, Level III Systems include, but are not limited to, the following requirements:

1. No more than four cylinders connected to a manifold at one time.
2. Enclosure for supply systems shall be provided with doors or gates that may be locked. (Ref. 4-3.1.2(1)(3))
3. Doors to supply system storage locations shall be provided with a louvered opening having a minimum area of 72 sq. in. (Ref. 4-3.1.2.3) or some other method which provides the same amount of venting.
4. Each cylinder of gas shall have a listed pressure regulator directly connected (Ref. 2.4.1(b)).
5. A pressure relief valve set at 50 percent above the normal operating pressure shall be installed downstream of each pressure regulator (Ref. 4-4.2.6).
6. A shut-off or check valve shall be installed downstream of each pressure regulator (Ref. 4-4.2.5).
7. A pressure gauge shall be installed in the main line and shall be appropriately labelled (Ref. 4-4.2.10.1).
8. Piping shall be seamless Type K or Type L (ASTM B88) copper tubing (Ref. 4-4.1.1.1(a))... shall be thoroughly cleaned of oil, grease... and be temporarily capped or plugged to prevent recontamination...(Ref. 4-4.1.4.1).
9. Flexible connectors of other than all-metal construction used to connect outlets of pressure regulators to fixed piping shall have a minimum burst pressure of 1000 PSIG (Ref. 4-5.2.3.2) and shall NOT penetrate walls, floors, ceilings or partitions. (Ref. 4-4.2.4)
10. Before closing of the walls, each section of the piping shall be subjected to a minimum test pressure of 150 PSIG with oil-free, dry air or nitrogen. This test pressure shall be maintained until each joint has been examined for leakage, and any leaks located shall be repaired and retested as above. After testing as above, the completely assembled piping system shall
be subjected to a 24-hour standing pressure test at 20 percent above the normal operating line pressure using required test gas.
11. Piping systems, shall deliver a minimum flow rate of 5 SCFM (141.6 SLPM) at rated pressure. (Ref. 4-5.1.3.3)
12. All brazed joints in the piping shall be made up using brazing filler alloys that bond with the base metals being brazed and that comply with the "Specifications for Brazing Filler Metal", ANSI/AWS A5.8.
 - (a) Copper -to- copper joints shall be made using a copper-phosphorus brazing filler alloy (BCuP series) without flux.
 - (b) Dissimilar metals such as copper and brass shall be joined using an appropriate flux with either a copper-phosphorus (BCuP series) or a silver (BAg series) brazing filler alloy. Apply flux sparingly and in a manner to avoid leaking any excess inside the completed joints. Use of prefluxed rod is acceptable (Ref. 4-4.1.4.2).
13. Gases used to power devices, such as in a compressed air or nitrogen system, as well as Level III vacuum systems, shall not be required to have an alarm system (Ref. 4-5.1.3.4(a)).
14. Where the central supply is remote from the medical gas systems use points, the main supply line shall be provided with a shut-off valve so located in the treatment facility as to be accessible from use-point locations in an emergency (Ref. 4-4.2.12.1).
15. Outlet stations shall be designed so that parts or components that are required to be gas specific cannot be interchanged between station outlets for different gases (Ref. 4-4.1.2.4(c)).
16. Labelling shall appear on the piping at intervals of not more than 20 ft. and at least once in each room and each story traversed by the piping systems (Ref. 4-6.4.1.1).

INITIAL PROCEDURE

1. Unpack Carefully.

2. Check for Damage.
3. Return Warranty Card Complete with Return Address. **WARRANTY VOID IF CARD NOT RETURNED.**

PLUMBER'S INSTRUCTIONS

1. **INSTALL OUTLET STATIONS IN DESIGNATED LOCATIONS.** See blueprint and Outlet Station Installation Instructions.
2. **INSTALL MANIFOLD IN TANK ROOM.** Bottom edge is 5 feet from the floor.
3. **RUN NITROGEN PIPING.**
 - a) Use type K or L, pre-cleaned, degreased, capped copper tubing only.
 - b) Use 3/8" O.D. tubing for Nitrogen lines.
 - c) Flow Nitrogen through lines while soldering. This will prevent oxidation from contaminating the line. Use Porter Nitrogen Test Fixture.

CAUTION
Use Medical grade dry Nitrogen only.
See Test Fixture instructions.

- d) Solder all joints. **Solder must have a melting point of at least 1000°F. Use silver solder or similar brazing alloy.**

CAUTION
Do not use corrosive flux! Use flux sparingly! Do not use flare, compression, or pipe fittings!

- e) Purge system before attaching Manifold.
- f) **DO NOT USE OIL OR GREASE.**
- g) Mark pipelines with gas name at least every 20 feet. 10 labels are provided by Porter with Manifold.
- h) When pipelines are concealed in a combustible wall, cover with conduit to protect from accidental puncture. (See tank room drawing)

4. **PORTER NITROGEN TEST FIXTURE INSTRUCTIONS - SOLDERING AND INITIAL LEAK CHECK**

- a) After spotting outlet stations in proper locations (see Porter Installation Instructions), connect hose to station.
- b) Attach Porter Nitrogen Test Fixture to Nitrogen Tank

CAUTION
Use medical grade dry nitrogen only.

- c) Remove dust cover cap from outlet station and connect hose to station.
- d) Set test fixture to "solder" position.
- e) **OPEN TANK SLOWLY.** The "solder" position allows very low flows of Nitrogen through the pipeline to prevent oxidation inside the line. The "purge" position flows a high volume to remove any foreign material before attaching the manifold.
- f) After soldering and purging the lines, attach the manifold and pressurize the system to 150 PSI to leak test.
- g) Check all joints with leak tester.
DO NOT USE SOAPY WATER - SOAP CONTAINS GREASE. Fix all leaks detected and re-check with leak tester.
- h) When no leaks are detected, proceed to System Pressure Test for Leaks (Section 5 below) and pressure test the system for 24 hours per NFPA 99. Contact the dental dealer or Porter Instrument Company if you have any further questions.

5. **SYSTEM PRESSURE TEST FOR LEAKS**

- a) Use medical grade dry Nitrogen.
- b) Test with Manifold in place and Outlet stations assembled.
- c) Fill system with 150 PSI.
- d) Disconnect Nitrogen tank and hoses.
- e) System should hold pressure for 24 hours (allow ± 5 PSI for temperature differences).
- f) If system does not hold pressure, test for leaks with leak tester at each joint. **DO NOT USE SOAPY WATER - SOAP CONTAINS GREASE.** Repair all leaks detected and repeat Steps 5.a through 5.f until no leaks are detected.

6. **TANK REGULATOR SETPOINT**

- a) Connect tank regulators and hoses supplied with the Nitrogen Manifold System as shown in Figure #1.

- b) **OPEN TANK VALVE SLOWLY** by turning counter-clockwise.
- c) Check the pressure to the Nitrogen Manifold System by reading the gauge on the Nitrogen Manifold. The pressure should be set to the rated pressure of the device being connected (no more than 100 PSIG). If the pressure needs to be increased, remove the cap on the tank regulator adjustment screw and turn the tank regulator adjustment screw clockwise until the gauge on the Nitrogen Manifold reads the required pressure. To decrease the pressure, turn the adjustment screw counter-clockwise. (Line pressure will require draining when decreasing regulator pressure.) Replace the adjusting screw cap after the pressure has been adjusted.
- d) Re-install the dust cover cap onto the outlet station

7. **AFTER DRYWALL IS INSTALLED.**

- a) Remove cover cap.
- b) Adjust the quick-connect by turning clockwise until the quick connect bottoms out. **HAND TIGHTEN ONLY, DO NOT USE A WRENCH.**
- c) Install cover plate.

CARPENTER'S INSTRUCTIONS

TANK ROOM

- 1. Must be in a separate room or cabinet.
- 2. A drywall stud wall will suffice.
- 3. Door should lock.
Room should be vented (72 sq. in. minimum). A vent in the door will suffice. Attach tank restrainers with lag screws. Install 40" from the floor. (See Figure #2)
- 4. Do not use tank room for compressor or other equipment.
- 5. Do not use tank room for storage of flammable material.

DEALER'S INSTRUCTIONS

- 1. Verify that the Nitrogen Manifold System has been leak checked.
- 2. Install the Tank Room Instructions label in the Tank Room.
- 3. Verify that the cover plates to the outlet stations are installed.

OPERATING INSTRUCTIONS

OVERVIEW

The Nitrogen Manifold System is a Nitrogen manifold that can handle from two to four tanks of Nitrogen. It can regulate the Nitrogen line pressure from 0 PSIG to 100 PSIG. It has several safety features which protect the patient, the operator and the equipment itself. The first of these features is the Nitrogen Manifold Pressure Relief valve, this begins to relieve at 150 PSIG \pm 15 PSIG. This device would normally be activated only when there was a pressure regulator failure. The second of these features is the Nitrogen Tank Pressure relief valve. This device begins to relieve at 200 PSIG \pm 20 PSIG. This device would normally be activated only when the pressure regulator and the Nitrogen Manifold Pressure Relief failed at the same time.

OPERATOR'S INSTRUCTIONS

1. NORMAL OPERATION
 - a) **OPEN TANK VALVE SLOWLY** by turning counter-clockwise. Open tank fully.
 - b) Check pressure on manifold gauge. Make sure it is at the required pressure for the device to be used. (NO MORE THAN 100 PSI). If not at required pressure, reset pressure per the Instruction for Setting the Regulator.
2. INSTRUCTIONS FOR SETTING THE REGULATOR
 - a) If the pressure needs to be increased, remove the cap on the tank regulator adjustment screw. Turn the tank regulator adjustment screw clockwise until the gauge on the Nitrogen Manifold reads the required pressure
 - b) To decrease the pressure, turn the adjustment screw counter-clockwise. (Line pressure will require draining when decreasing regulator pressure.)
 - c) Replace the adjusting screw cap after the pressure has been adjusted.

NITROGEN MANIFOLD SYSTEM SPECIFICATIONS

GENERIC PROPERTIES:

1. Manifold pressure relief valves set at 50 percent (150 PSIG) above the maximum line pressure (100 PSIG) for operatory equipment protection (REF. NFPA 99, 1996 Edition, 4-5.1.2.5).
2. Nitrogen gauge, 0 - 160 PSIG to track line pressure.
3. Nitrogen Quick Disconnect connections with check valve assembly installed downstream of each outlet station (Two types Imperial and Schrader).
4. Tank regulators must be set at no more than 100 PSIG regulated pressure to insure normal operation.
5. Tank regulator pressure relief valves set at 100 percent (200 PSIG) above the maximum line pressure (100 PSIG) for operatory equipment protection.
6. The Nitrogen Manifold System must be able to achieve a minimum flow rate of 5 cubic feet per minute (approximately 141 liters per minute). (REF. NFPA 99, 1996 Edition, 4-3.4.1.3(c)(3))
7. Only type K or L, pre-cleaned, degreased, capped copper tubing may be used.
8. All joints must be silver soldered at 1000°F melting point. Use a minimum amount of flux.
9. Construction: 3/8" O.D. copper tubing from manifold. 3/8" O.D. copper tubing to outlet stations.

ENVIRONMENTAL LIMITS

1. Limited to four Nitrogen tanks.
2. No oil may be used in the system.
3. Temperature Operation: 15°F - 140°F
4. Pressure Limitations: 0 - 200 PSIG

FIGURE 1 — NITROGEN MANIFOLD SYSTEM LAYOUT

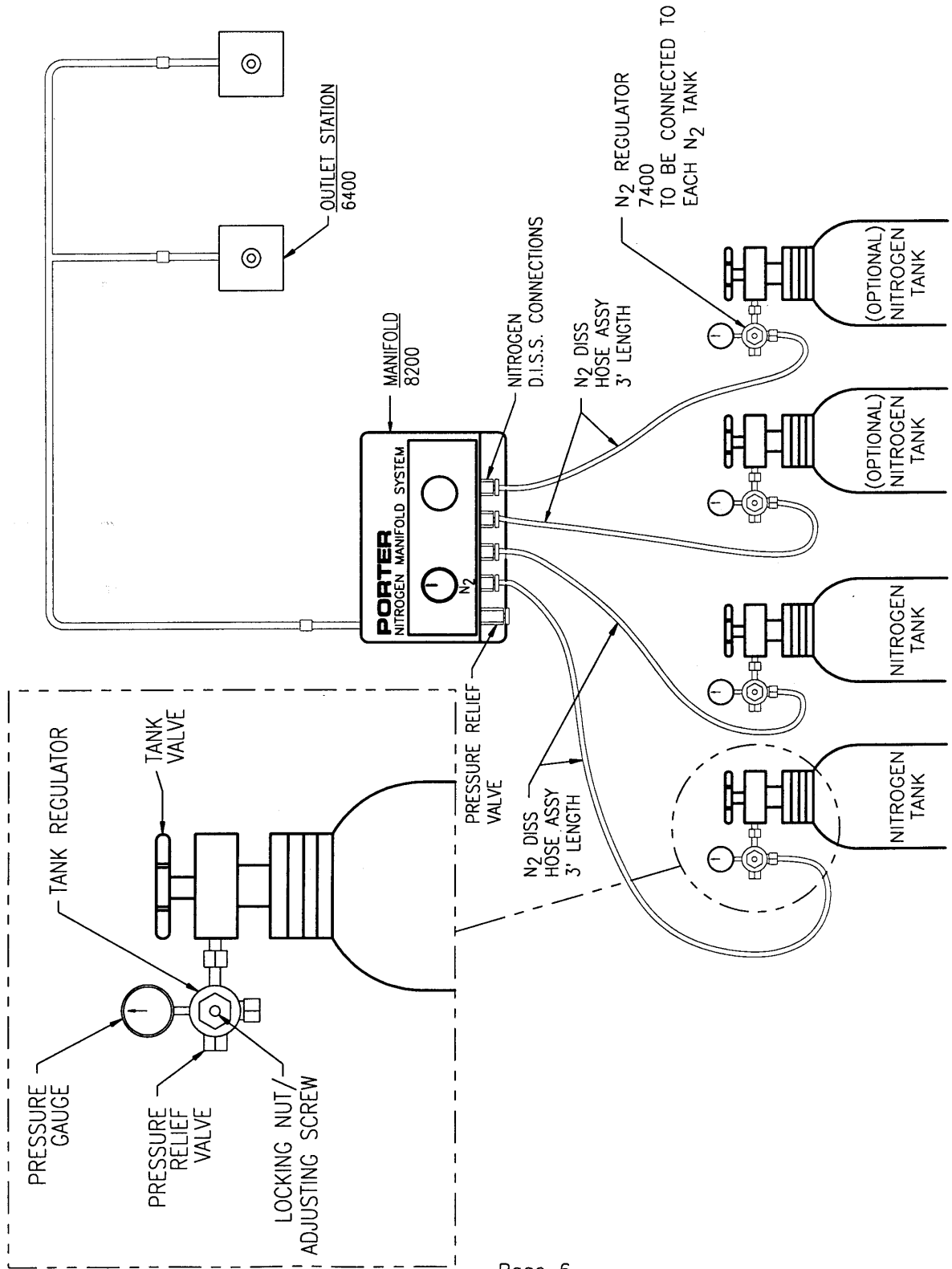
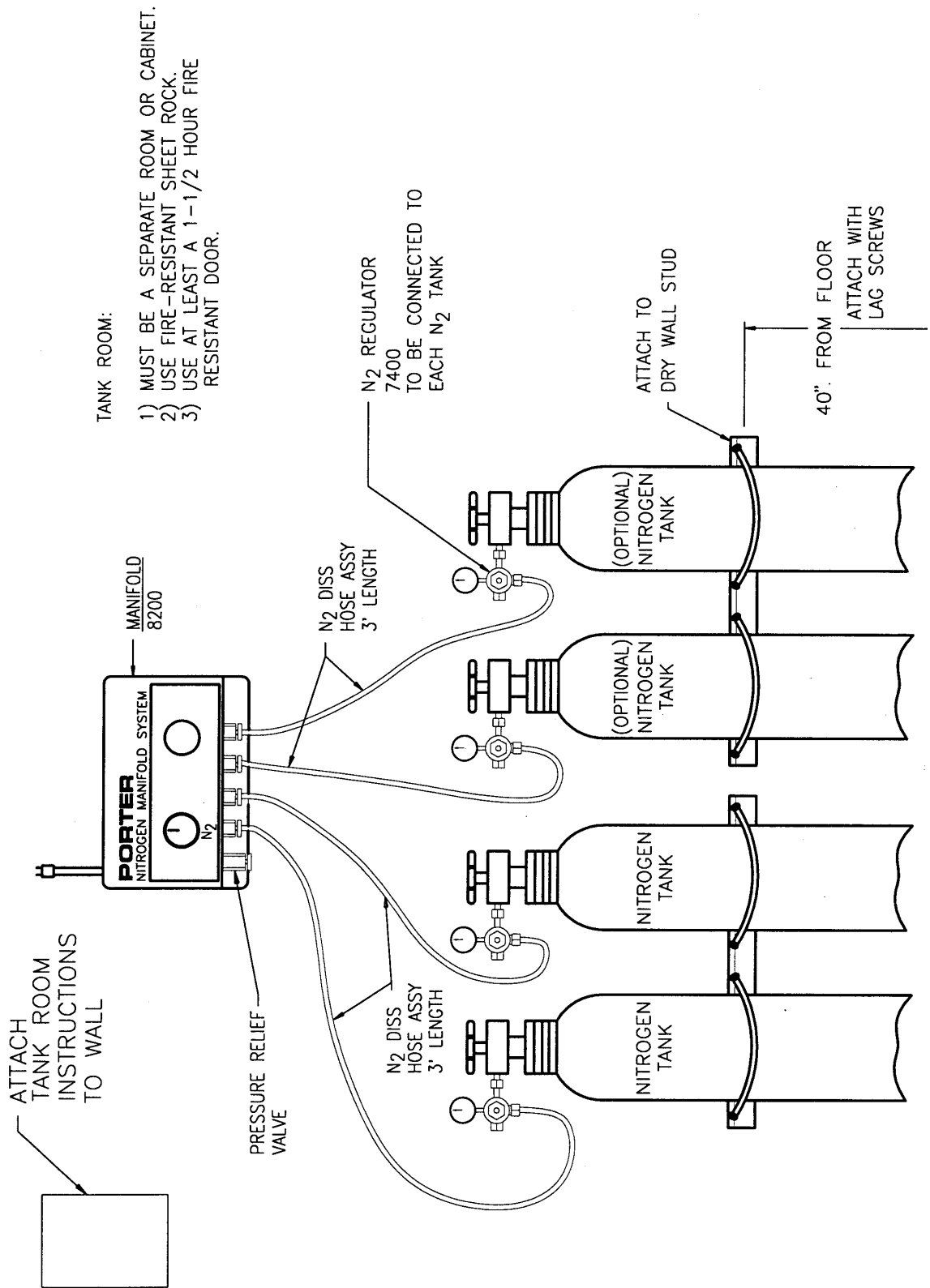

FIGURE 2 -- TANK ROOM AREA



TANK ROOM:

- 1) MUST BE A SEPARATE ROOM OR CABINET.
- 2) USE FIRE-RESISTANT SHEET ROCK.
- 3) USE AT LEAST A 1-1/2 HOUR FIRE RESISTANT DOOR.

For further Technical assistance on this or any other Porter Dental product, write or call --

PORTER
INSTRUMENT
COMPANY, INC.

245 TOWNSHIP LINE RD
PO BOX 907
HATFIELD, PA 19440-0907
[215] 723-4000 • FAX [215] 723-5106