

**Nitrous Oxide Sedation Systems
INSTALLATION**

SENTINEL

**3222 CX/DX
MANIFOLD SYSTEM**

PORTER INSTRUMENT COMPANY, INC.

245 TOWNSHIP LINE RD. P.O. BOX 907 HATFIELD, PA 19440-0907 USA [215] 723-4000 / FAX [215] 723-2199

PORTER 3222 CX/DX "SENTINEL" MANIFOLD SYSTEM

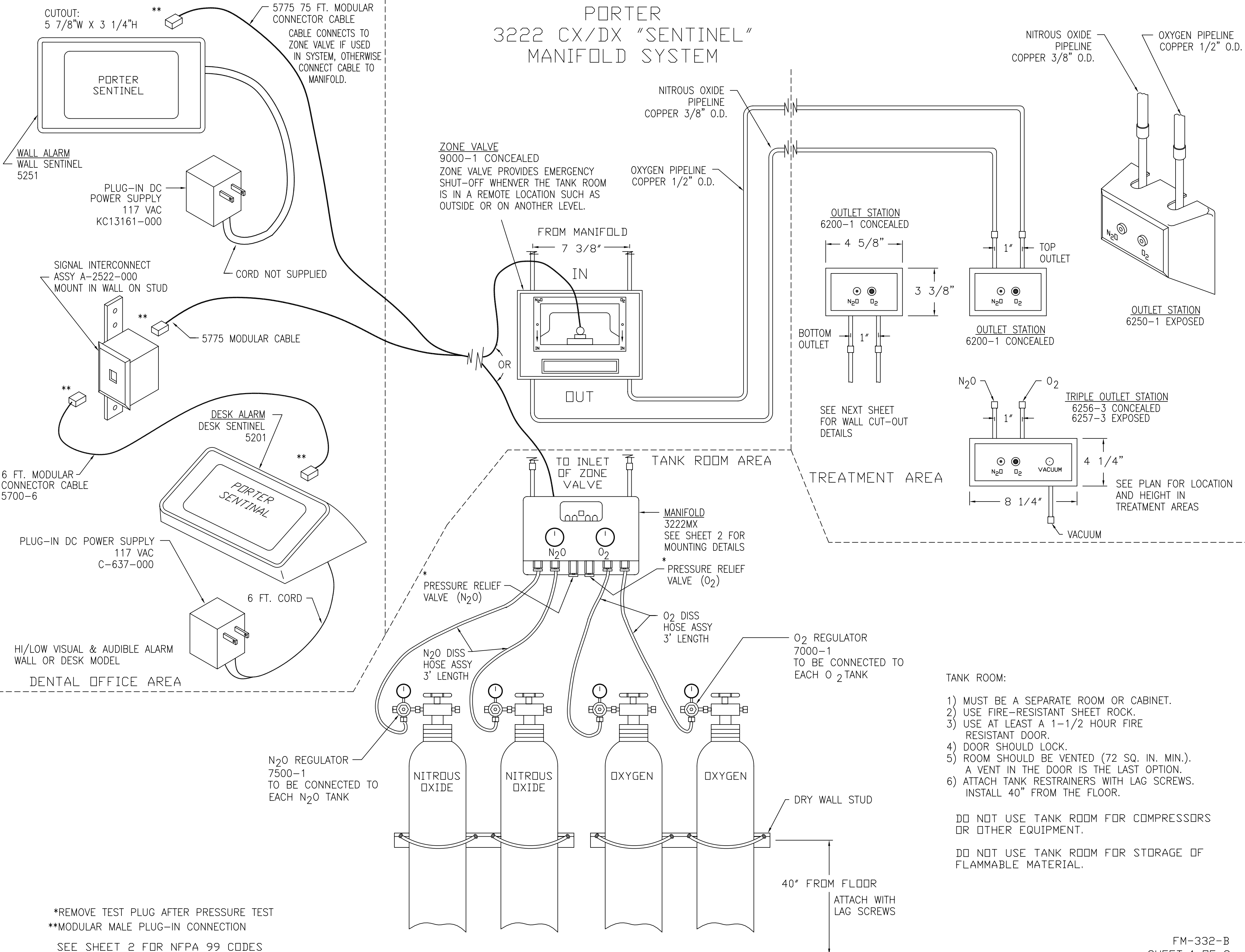

- TANK ROOM:**
- 1) MUST BE A SEPARATE ROOM OR CABINET.
 - 2) USE FIRE-RESISTANT SHEET ROCK.
 - 3) USE AT LEAST A 1-1/2 HOUR FIRE RESISTANT DOOR.
 - 4) DOOR SHOULD LOCK.
 - 5) ROOM SHOULD BE VENTED (72 SQ. IN. MIN.). A VENT IN THE DOOR IS THE LAST OPTION.
 - 6) ATTACH TANK RESTRAINERS WITH LAG SCREWS. INSTALL 40" FROM THE FLOOR.

DO NOT USE TANK ROOM FOR COMPRESSORS OR OTHER EQUIPMENT.

DO NOT USE TANK ROOM FOR STORAGE OF FLAMMABLE MATERIAL.

*REMOVE TEST PLUG AFTER PRESSURE TEST
 **MODULAR MALE PLUG-IN CONNECTION
 SEE SHEET 2 FOR NFPA 99 CODES

- 1) USE TYPE K OR L, PRE-CLEANED, DEGREASED, CAPPED COPPER ONLY.
- 2) USE SILVER SOLDER OR SIMILAR BRAZING ALLOY WITH AT LEAST A 1000°F MELTING POINT ONLY.
- 3) TEST FOR LEAKS WITH DRY NITROGEN AT 150 PSI FOR 24 HOURS.

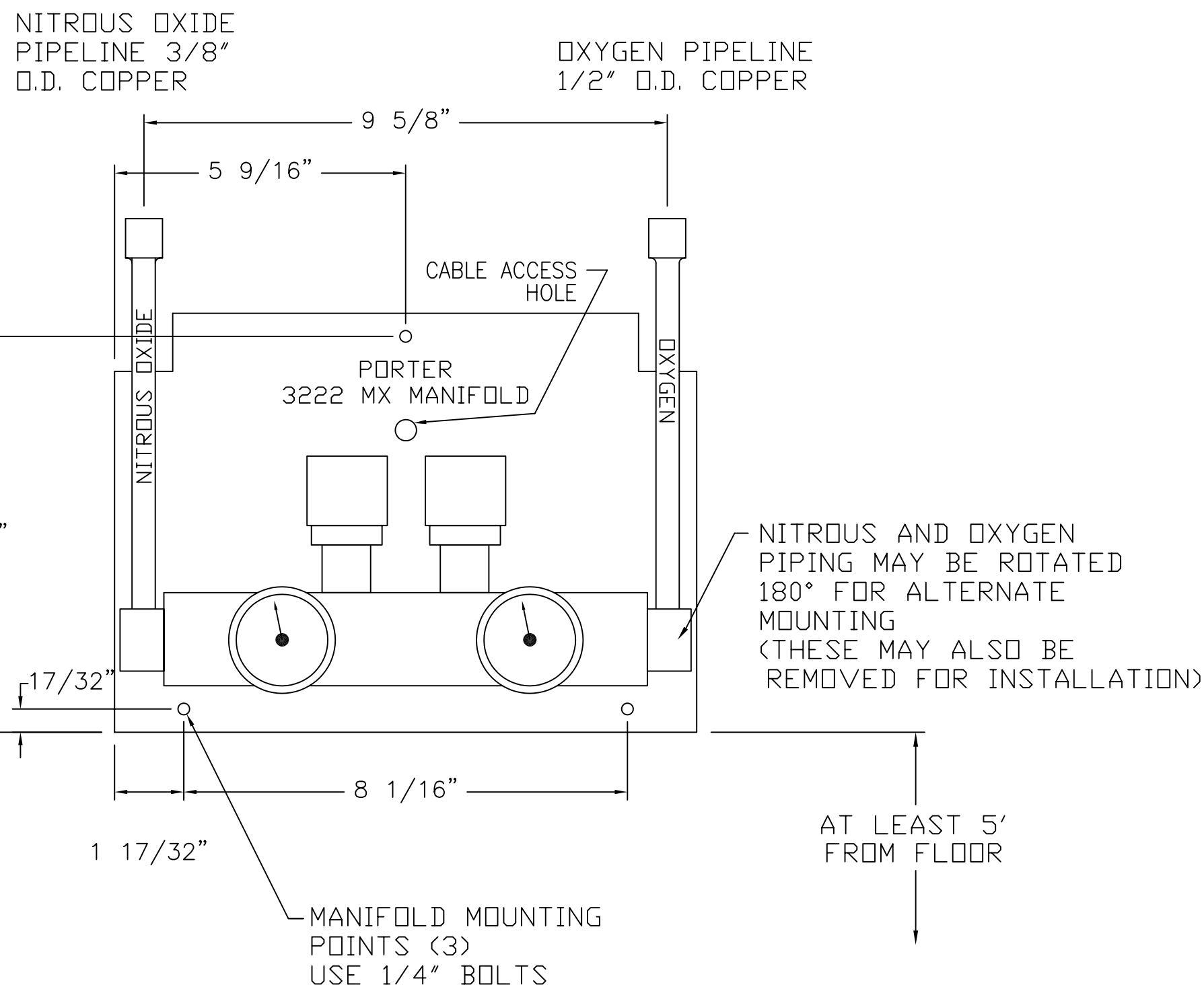

NFPA 99 CODES

TO ASSURE SAFE OPERATION AND CONFORMANCE TO LOCAL FIRE CODES, PORTER INSTRUMENT CO. NITROUS OXIDE SEDATION SYSTEMS MEET OR EXCEED THE GUIDELINES ESTABLISHED BY THE NATIONAL FIRE PROTECTION ASSOCIATION FOR NONFLAMMABLE MEDICAL GAS SYSTEMS, NFPA 99. COPIES OF NFPA 99 OR PORTIONS THEREOF MAY BE OBTAINED BY WRITING TO: NATIONAL FIRE PROTECTION ASSOCIATION, BATTERYMARCH PARK, QUINCY, MA 02269-9904 OR CALL: 1-800-344-3555

LEVEL 3 NONFLAMMABLE MEDICAL GAS SYSTEMS INCLUDE, BUT ARE NOT LIMITED TO, THE FOLLOWING REQUIREMENTS:

1. NO MORE THAN 3000 CU. FT. TOTAL CAPACITY OF ALL GASES (EXCLUDING NITROGEN) CONNECTED AND IN STORAGE AT ONE TIME...
2. ENCLOSURE FOR SUPPLY SYSTEM STORAGE SHALL BE PROVIDED WITH DOORS OR GATES THAT MAY BE LOCKED.
3. DOORS TO SUPPLY SYSTEM STORAGE LOCATIONS SHALL BE PROVIDED WITH A LOUVERED OPENING HAVING A MINIMUM OF 72 SQ. IN. TOTAL FREE AREA. BUT, LOUVER IS ONLY NEEDED WHEN NO OTHER VENTING IS POSSIBLE.
4. EACH CYLINDER OF GAS SHALL HAVE A LISTED PRESSURE REGULATOR DIRECTLY CONNECTED.
5. A PRESSURE RELIEF VALVE SET AT 50 PERCENT ABOVE (75 P.S.I.G.) NORMAL LINE PRESSURE (50 P.S.I.G.).
6. A SHUT-OFF VALVE OR CHECK VALVE SHALL BE INSTALLED DOWNSTREAM OF EACH PRESSURE REGULATOR.
7. A PRESSURE GAUGE SHALL BE INSTALLED IN THE MAIN LINE ADJACENT TO THE ACTUATING SWITCH... IT SHALL BE APPROPRIATELY LABELED...
8. PIPING SHALL BE SEAMLESS TYPE K OR L (ASTM B88) COPPER TUBING... SHALL BE THOROUGHLY CLEANED OF OIL, GREASE...AND BE CAPPED OR PLUGGED TO PREVENT RECONTAMINATION...
9. FLEXIBLE CONNECTORS OF OTHER THAN ALL-METAL CONSTRUCTION USED TO CONNECT OUTLETS OF PRESSURE REGULATORS TO FIXED PIPING SHALL HAVE A MINIMUM BURST PRESSURE OF 1000 P.S.I.G. AND SHALL NOT PENETRATE WALLS, FLOORS, CEILINGS, OR PARTITIONS.
10. BEFORE CLOSING OF THE WALLS, EACH SECTION OF THE PIPING SYSTEM SHALL BE SUBJECTED TO A MINIMUM TEST PRESSURE OF 150 P.S.I.G. WITH OIL-FREE, DRY AIR OR NITROGEN. THIS TEST PRESSURE SHALL BE MAINTAINED UNTIL EACH JOINT HAS BEEN EXAMINED FOR LEAKAGE, AND ANY LEAKS LOCATED SHALL BE REPAIRED AND RETESTED AS ABOVE. AFTER TESTING AS ABOVE, THE SOURCE SHUTOFF VALVE SHALL THEN BE CLOSED. THE TEST SHALL REMAIN STATIC FOR A PERIOD OF 24 HOURS WITH A MAXIMUM ALLOWABLE PRESSURE LOSS OF 5 PSIG.
11. PIPING SYSTEMS, WITH THE EXCEPTION OF NITROGEN SYSTEMS, SHALL BE CAPABLE OF DELIVERING 50 TO 55 P.S.I.G. TO ALL OUTLETS AT THE MAXIMUM FLOW RATE.
12. ALL BRAZED JOINTS IN THE PIPING SHALL BE MADE UP USING BRAZING FILLER ALLOYS THAT BOND WITH THE BASE METALS BEING BRAZED AND THAT COMPLY WITH "SPECIFICATIONS FOR BRAZING FILLER METAL," ANSI/AWS A5.8.
 - (a) COPPER-TO-COPPER JOINTS SHALL BE MADE USING A COPPER-PHOSPHOROUS BRAZING FILLER ALLOY (BCuP SERIES) WITHOUT FLUX
 - (b) DISSIMILAR METAL SUCH AS COPPER AND BRASS SHALL BE JOINED USING AN APPROPRIATE FLUX WITH EITHER A COPPER-PHOSPHOROUS (BCuP SERIES) OR A SILVER (BAg SERIES) BRAZING FILLER ALLOY. APPLY FLUX SPARINGLY AND IN A MANNER TO AVOID LEAKING ANY EXCESS INSIDE OF COMPLETED JOINTS. USE OF PREFLUXED ROD IS ACCEPTABLE.
13. AUDIBLE AND NON-CANCELLABLE VISUAL SIGNALS SHALL INDICATE IF THE PRESSURE IN THE MAIN LINE INCREASES OR DECREASES 20 PERCENT FROM THE NORMAL OPERATING PRESSURE, AND SHALL BE INSTALLED IN THE OFFICE OR PRINCIPAL WORKING AREA OF THE INDIVIDUAL RESPONSIBLE FOR THE MAINTENANCE OF THE MEDICAL GAS SYSTEM AND, TO ASSURE CONTINUOUS SURVEILLANCE.
14. WHERE THE CENTRAL SUPPLY IS REMOTE FROM THE MEDICAL GAS SYSTEMS USE POINT, THE MAIN SUPPLY LINE SHALL BE PROVIDED WITH A SHUT-OFF VALVE SO LOCATED IN THE TREATMENT FACILITY AS TO BE ACCESSIBLE FROM THE USE-POINT LOCATIONS IN AN EMERGENCY.
15. OUTLET STATIONS SHALL BE DESIGNED SO THAT PARTS OR COMPONENTS THAT ARE REQUIRED TO BE GAS SPECIFIC CANNOT BE INTERCHANGED BETWEEN STATION OUTLETS FOR DIFFERENT GASES.
16. LABELING SHALL APPEAR ON THE PIPING AT INTERVALS OF NOT MORE THAN 20 FT. AND AT LEAST ONCE IN EACH ROOM AND EACH STORY TRAVERSED BY THE PIPING SYSTEMS.

WALL CUT-OUTS

