

MONTHLY CHECK

Leak test the entire system for working pressure leaks. Connect an 8060 series duplex connector and hoses into the Triple Outlet Station. Attach the other end of the hoses to a flowmeter and turn the flow control knobs to the off position and the on/off switch to the off position. Pressurize the sedation gas supply lines with 50 PSI. Observe any pressure decay after 12 hours. This 50 PSI test with the flowmeter tubing connections in place tests the seal of the duplex connector extended into the o-rings of the outlet station primary check valves. (5 PSI drop allowed.)

SERVICE PRIMARY AND SECONDARY CHECK VALVE ASSEMBLIES

The Oxygen and Nitrous Oxide primary and secondary check valve assemblies may be field disassembled and replaced.

- | | |
|-----------------------------------|--|
| 1) Primary Check Valve Assembly | O ₂ A-2689-000
N ₂ O A-2690-000 |
| 2) Cartridge Body | O ₂ B-2237-000
N ₂ O B-2275-000 |
| 3) 016 O' Ring | PB-102-215 |
| 4) Secondary Check Valve Assembly | A-2699-000 |
| 5) Compression Spring | PB-115-63SS |

PRIMARY CHECK VALVE DISASSEMBLY INSTRUCTIONS

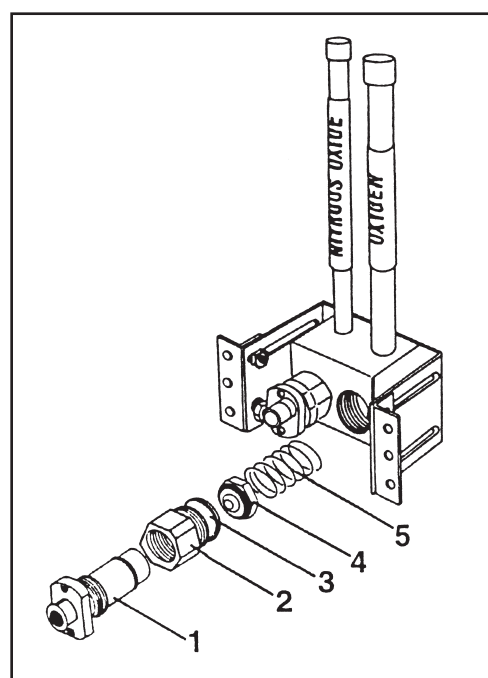

SERVICE PRIMARY CHECK VALVE

May be serviced with station pressurized to 50 PSI.

- Remove front plate. Mounting screws are behind plate labels.
- Unscrew the primary check valve assembly. Oxygen right hand threads; Nitrous Oxide left hand threads. **Note: the secondary check valve will move into position and seal the 50 PSI of the station pressure as the primary check valve assembly is removed.**



WARNING

Do not remove the cartridge body while servicing the primary check valve assembly. The secondary check valve cannot seal the 50 PSI pressure if the cartridge body is removed.

- Replace the entire assembly.
- Screw the replaced assembly into the cartridge body.
- Alignment & Adjustment for Front Plate Installation – The Oxygen and Nitrous Oxide Valve Bodies are factory adjusted to allow for the back of the Front Plate to press against the metal surfaces of all three valve bodies. If adjustment is needed, follow these steps:
 - Rotate the Oxygen and Nitrous Oxide valve bodies so they both uniformly contact the back of the Front Plate. Oxygen has right hand threads and Nitrous Oxide has left hand threads.
 - Adjust the right hand thread vacuum valve body to align with the metal surfaces of the other valve bodies.
- Leak test the entire system for working pressure leaks per the Monthly Check.**

SECONDARY CHECK VALVE DISASSEMBLY INSTRUCTIONS

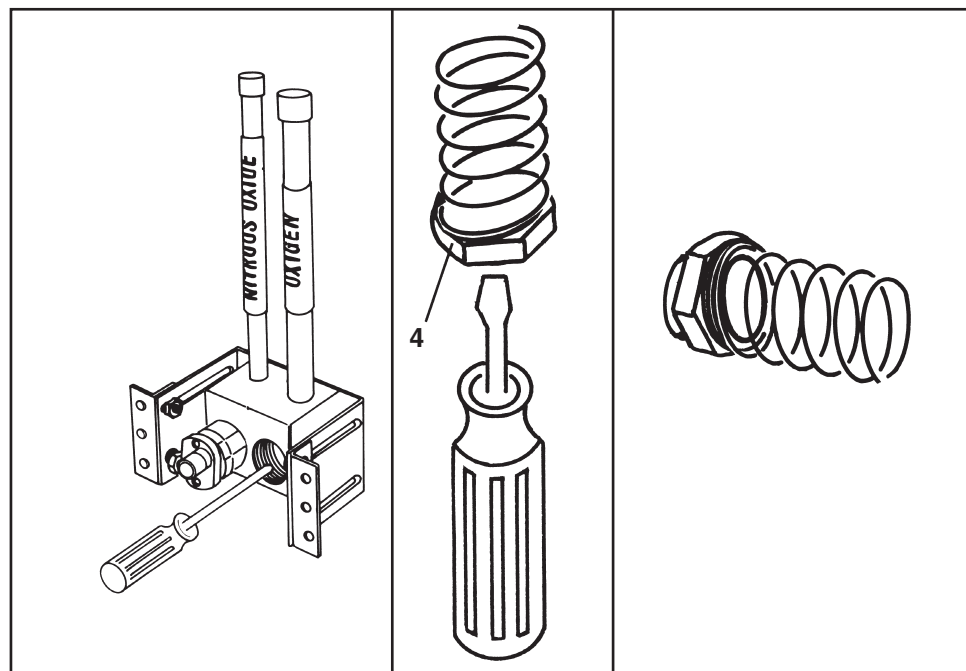

SERVICE SECONDARY CHECK VALVE



WARNING

To service the secondary check valve, first turn off pressure. Do not remove the cartridge body until the pressure is bled off. The secondary check valve cannot seal the 50 PSI pressure if the cartridge body is removed.

- Turn off pressure at tanks in tank room.**
- Follow procedure to remove primary check valve assembly.
- Depress secondary check valve further into station block using a small probe or screw driver to bleed off pressure.
- Unscrew cartridge body out of the station block.
- Take a small screw driver or needle nose pliers and insert into holes at the center of secondary check valve. Carefully remove check valve and spring.
- Replace the 016 o-ring and secondary check valve parts as required and place in position for reassembly.
- Screw in the cartridge body and tighten.
- Screw in the primary check valve assembly and align and adjust for front plate installation.
- Leak test the entire system for working pressure leaks per the Monthly Check.**



TRIPLE OUTLET STATION INSTALLATION AND INSTRUCTIONS

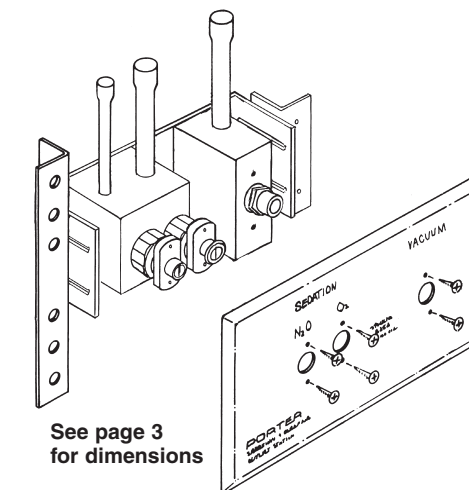

See page 3 for dimensions

STATION INSTALLATION INSTRUCTIONS

- LOCATION:** Select appropriate location for mounting station to a stud prior to installing drywall or wall board. Secure bracket "A" to stud. (Fig. 1)



WARNING

Porter Instrument Outlet Stations utilize the **cross+protection** system. The copper tubing is diameter indexed; 3/8" O.D. for Nitrous Oxide and 1/2" for Oxygen. The **cross+protection** system is designed to prevent misconnection of Oxygen and Nitrous Oxide piping. **DO NOT ATTEMPT TO CHANGE THE DIAMETERS!** Tampering with the **cross+protection** system constitutes acceptance of liability by the installer. For your own protection, as well as that of the Doctor and the patients, use 3/8" O.D. tubing for all Nitrous Oxide lines and 1/2" O.D. tubing for all Oxygen lines.

To assure safe operation and conformation to local fire codes, all Porter Instrument Outlet Stations are designed to be used with sedation delivery systems mounted inside walls and they meet or exceed the guidelines established by the National Fire Protection Association for Nonflammable Medical Gas Systems, NFPA 99. Copies of NFPA 99 or portions thereof may be obtained by writing to:

National Fire Protection Association
Batterymarch Park
Quincy, MA 02269-9904
Or call: 1-800-344-3555

The Porter Triple Outlet Station (6256-3) provides a quick, safe, and reliable method of connection to both Porter Sedation and Clean-Air™ outlet service. The 6256-3 provides all the service features of the Porter 6200-1 N₂O/O₂ outlet station, and the Porter 5600-3 Clean-Air outlet station. Features include the **cross+protection** system to prevent unintentional misconnection to the central piping system. The outlet station utilizes a duplex connector which prevents the Nitrous Oxide from being connected unless the Oxygen is connected, and offers resuscitator quick connect compatibility. Compact stainless steel face plate is color coded for instant gas identification. A qualified plumber should install the outlet.

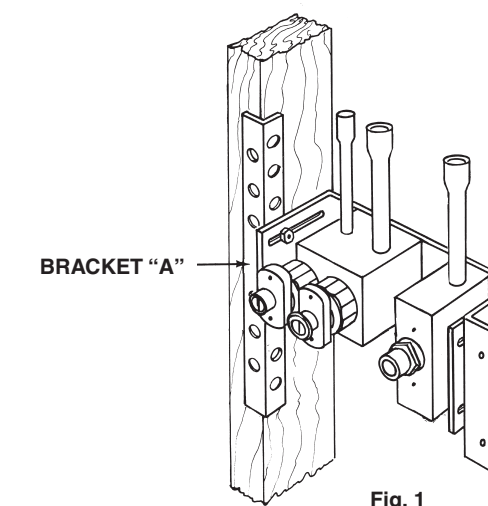

Fig. 1



WARNING

Dental workers are exposed to N₂O during administration of N₂O/O₂ conscious sedation analgesia. NIOSH has recommended that exposures should be minimized. Contact NIOSH (1-800-35-NIOSH) to receive NIOSH Publications on *Control of Nitrous Oxide in Dental Operatories*. Exposure can be minimized by effective controls. National Institute for Occupational Safety and Health (NIOSH) publications state that controls, including System Maintenance, Ventilation and Work Practices can effectively reduce N₂O concentrations in dental operations. Your Porter Scavenger System is an important part of the system of controls.

2. PIPING REQUIREMENTS

2.1. Sedation Outlet Connections (N₂O/O₂)

This portion of the 6256-3 outlet station has the option of unscrewing the gas block, (N₂O/O₂) (Fig. 2) from the support plate (three screws), inverting the block (Fig. 3) so the pipes may extend downward (Fig. 4).

2.2. **IMPORTANT:** When remounting the blocks to the support plate use the *lower* set of holes on the plate (Fig. 4) to insure the faceplate will line up. (Note: This is only when pipes are pointing down.)

2.3. Pipes can then be joined to their appropriate 3/8" OD tube for Nitrous Oxide, and 1/2" OD tube for Oxygen. (See section below.)

2.4. **Central Suction Powered Systems:** Determine the direction in which the piping is needed.

2.5. If the vacuum tube (1/2" OD) is required in the upward position, be aware that moisture could drain back into the tubing. It is recommended that a trap be used.

2.6. If the vacuum tube (1/2" OD) is required in the downward position, unscrew the vacuum block from the support pole (two screws), invert the block (Fig. 5) and screw the vacuum block back onto the support plate.

2.7. **IMPORTANT:** When remounting the block to the support plate use the *upper* set of holes on the plate. (Note: This is only when pipe is pointing down.)

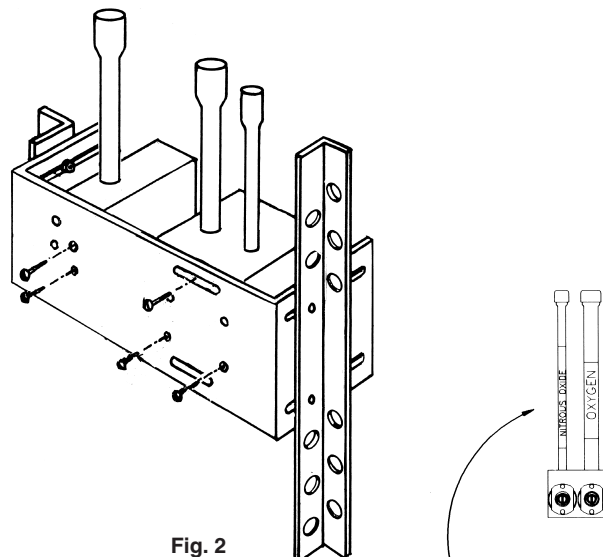

Fig. 2



Fig. 3

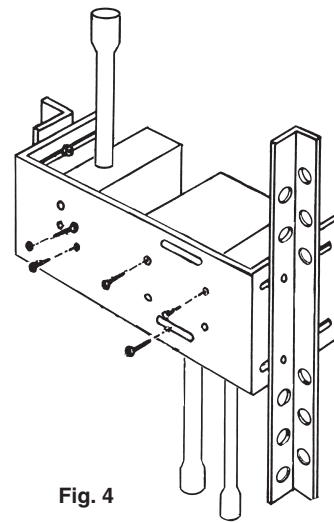

Fig. 4

3. DRYWALL OR WALL BOARD CUT-OUT AND STATION FIXTURING DETAILS

- 3.1. Closing up walls requires a 2 3/4" H. x 6 3/8" L. cut-out opening. See template diagram for actual cut-out outline.
- 3.2. Bracket "B" butts up to underside of drywall. Pan Head tapping screws with washers, pinch drywall in place for fastening right end of unit securely.

4. INSTALL THE GAS SUPPLY LINES:

Note: The station is designed and intended to be used with gas supply lines installed using NFPA 99 guidelines, including a 150 PSI piping integrity test. Medical grade dry Nitrogen should be used as a "forming gas" while soldering. To prevent oxidation inside supply lines:

- (a) Use type K or L, pre-cleaned, degreased, capped copper tubing **ONLY**.
- (b) Use 3/8" O.D. for Nitrous Oxide; use 1/2" O.D. for Oxygen. **DO NOT CHANGE TUBING DIAMETERS!!**
- (c) All copper to copper joints are to be made using a brazing allows conforming to AWS Classification BcuP-5 (see AWS Std. A5.8). Flux shall not be used.
- (d) After connecting all gas lines, check the system for leaks with dry Nitrogen per NFPA 99.

5. **Check for Crossed Lines.** (Refer to NFPA Gas and Vacuum Systems Code for Type II Systems) (See **cross+protection Warning** in this brochure.)

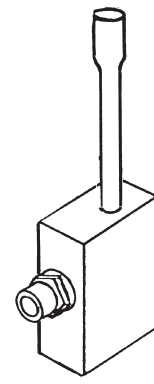
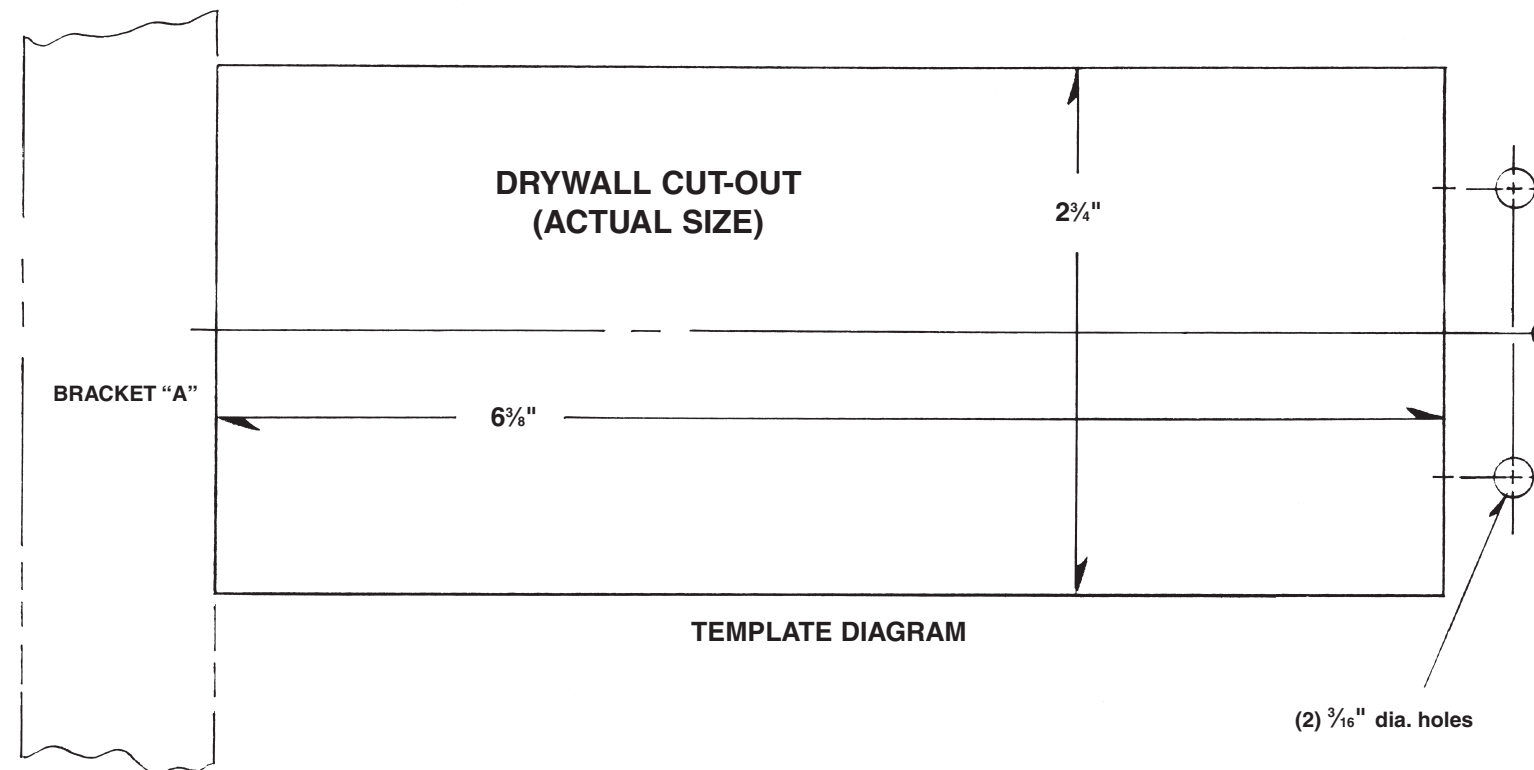
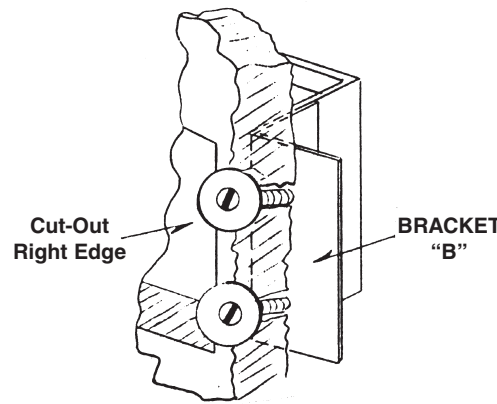
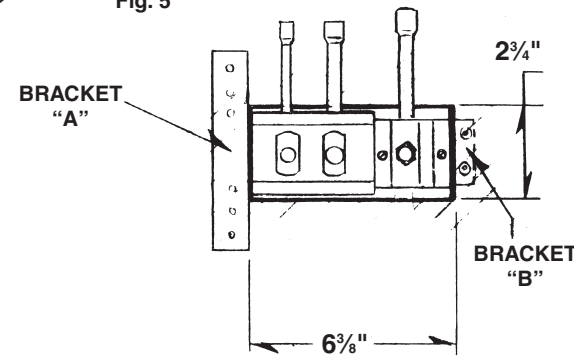
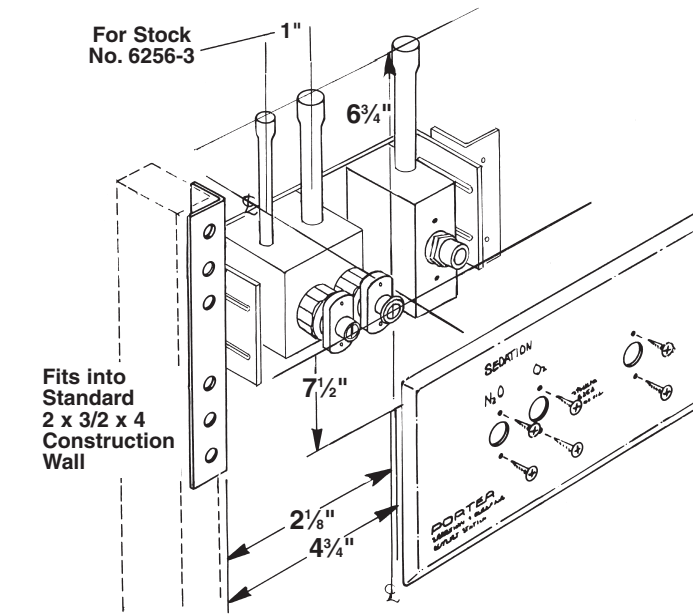
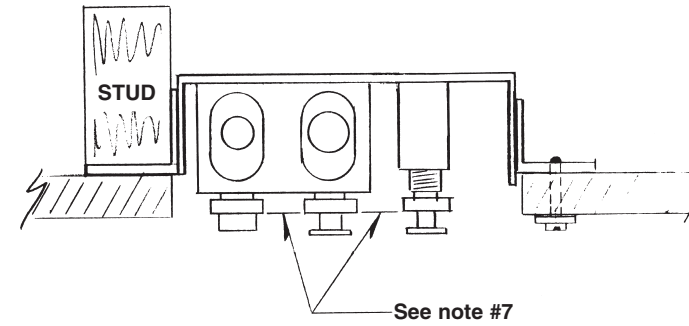

Fig. 5



AFTER DRY WALL IS INSTALLED

6. Remove cover cap. Check to make sure leading edge of box is flush with dry wall. If U shaped bracket is incorrectly aligned, loosen bracket mounting nuts with a 3/8" open end wrench, adjust to fit, re-tighten nuts.
7. Alignment & Adjustment for Front Plate Installation – The Oxygen and Nitrous Oxide Valve Bodies are factory adjusted to allow for the back of the Front Plate to press against the metal surfaces of all three valve bodies. If adjustment is needed, follow these steps:
 - 7.1. Rotate the Oxygen and Nitrous Oxide valve bodies so they both uniformly contact the back of the Front Plate. Oxygen has right hand threads and Nitrous Oxide has left hand threads.
 - 7.2. Adjust the right hand thread vacuum valve body to align with the metal surfaces of the other valve bodies.



8. Install Front Plate with the six 4-40 flat head screws.
9. Apply diameter indexed N₂O/O₂ gas label in place over diameter indexed check valve connector bushings. Pull off center strip backing, and press label in place. Remove top and bottom backing strips, and finish securing label.

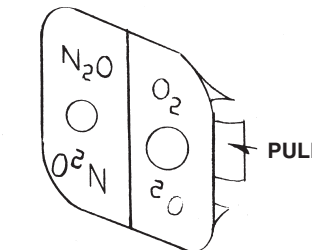

10. Connect an 8060 series duplex connector and hoses into the completely assembled Triple Outlet Station. Attach the other end of the hoses to a flowmeter and turn the flow control knobs to the off position and the on/off switch to the off position.
11. **Leak test the entire system for working pressure leaks.** Pressurize the sedation gas supply lines with 50 PSI. Observe any pressure decay after 12 hours. This 50 PSI test with the flowmeter tubing connections in place tests the seal of the duplex connector extended into the o-rings of the outlet station primary check valves. (5 PSI drop allowed.)
12. Attach the appropriate vacuum lines from the HVE attachment to the station vacuum line.

CONNECTIONS TO FLOWMETER – OPERATING INSTRUCTIONS

Flowmeter Gas Supply Tubing and Vacuum Tubing is connected to the Triple Outlet Station via two quick connect couplers. The Porter 8060 series duplex connector simultaneously connects the Oxygen and Nitrous oxide tubing, and prevents the Nitrous Oxide from being connected unless the Oxygen is connected. The Porter 5602 vacuum quick connect with hose barb separately inserts into the vacuum check valve of the station.

QUICK CONNECTING

You may quick connect to the station when the system pressure is at its normal 50 PSI; the primary check valves seal this pressure. Both couplers have locating latches. Simply insert the couplers into the appropriate check valve and confirm the latch is in place behind the catch feature of the valve. A gentle tug on the coupler will confirm a stable latch position. Internally, within the primary check valve, an o-ring seals against a poppet. The same o-ring seals against the quick connect extensions upon insertion. Slide the latch out of position to remove the connector and the internal poppet will automatically move back into its sealing position.

RESUSCITATOR

Remove the duplex connector so a resuscitator quick connects may be inserted into the oxygen station position.

MAINTENANCE AND SERVICE

Use Scavenging

Monitor for N₂O in the operator to insure that controls are effective in achieving low levels of ppm (parts per million) exposure. Contact your Porter dealer for details on monitors and testing.

Inspect and maintain the analgesia delivery system to prevent N₂O leaks in all hoses, connections and fittings. Repair all leaks immediately.